

Serie DAC. Rodamientos de doble hilera de bolas con contacto angular

El rodamiento **Koyo** del tipo DAC es un rodamiento de doble hilera de bolas con contacto angular que incorpora un anillo externo integrado y dos anillos internos separables, estos rodamientos están disponibles con obturación y sin obturación (diseño inicial). La serie DAC es conocida como la primera generación, posterior a las aplicaciones convencionales de rodamientos rígidos de bolas (o rodillos cónicos) individuales.

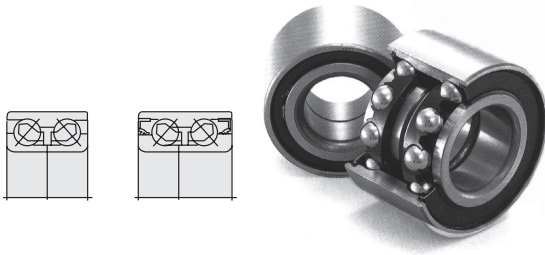

Cuentan con numerosas ventajas, entre ellas:

- ◆ **No es necesario el ajuste de la precarga durante el montaje**
Luego del montaje del rodamiento sobre el eje, solo es necesario apretar las tuercas con el torque (par torsional) específico.
- ◆ **Compacto y de alto rendimiento**
No se requieren partes adicionales (como los espaciadores), minimizando los requerimientos de espacio axial.

Por esta condición, se pueden usar ejes cortos y de alta rigidez.

- ◆ **No es necesario rellenar de grasa durante el montaje**
- ◆ **Alta productividad**
El número de partes está reducido con la consecuente simplificación del trabajo de montaje.
- ◆ **Alta resistencia al momento de flexión**
Este rodamiento ha sido diseñado con un ángulo de contacto amplio, por lo cual debido a la gran distancia entre los centros de presión (dimensión "a" en algu-

nas tablas) este rodamiento es altamente resistente en momentos flectores impuestos sobre las ruedas durante las curvas o movimientos similares. Gracias a este diseño especial, la rigidez ha sido mejorada por la gran resistencia a los momentos de flexión del rodamiento.

- ◆ **Gran capacidad de carga**
Este rodamiento es resistente a las cargas radiales y axiales en ambas direcciones.
- ◆ **Juego axial interno apropiado**
Debido a que el rodamiento está diseñado para tener el juego axial interno apropiado, no hay necesidad de ajuste de la precarga (ajuste dimensional por espaciadores) lo que sí es necesario para el montaje de los rodamientos de una hilera de bolas.
- ◆ **Engrasado**
Una cantidad apropiada de grasa de alta calidad [excelente para condiciones de calor (130°C) y resistencia al desgaste] se coloca en el rodamiento.
- ◆ **Obturación superior**
Estos rodamientos obturados han sido sometidos a ensayos de resistencia a la penetración de fango, polvo y de escape de la grasa; todos sin el uso de los sellos del eje.
- ◆ **Confiabilidad mejorada**
El acero **Koyo** HRS (High Refining Steel / Acero altamente refinado) puede usarse para este rodamiento, extendiendo así su vida útil.

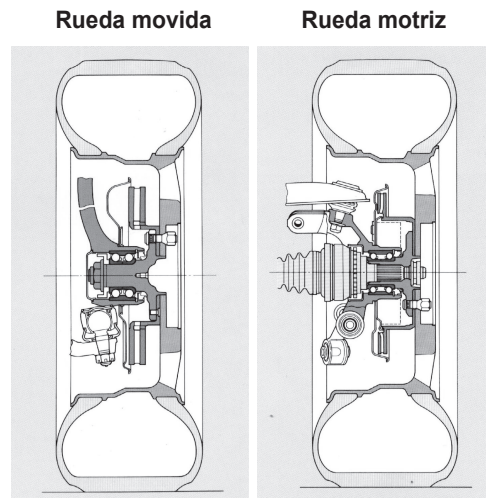

SISTEMA DE DESIGNACIÓN

DAC 00 00 (00)

- Nombre de la serie DAC (Double row Angular Contact Ball Bearing)/ Rodamiento de doble hilera con contacto angular.
- Diámetro del agujero en el a.i. en mm (d)
- Diámetro externo del a.e. en mm (D)
- Ancho del rodamiento en mm (cuando aparecen estos dígitos) (B)

▶ RODAMIENTOS AUTOMOTRICES

Serie DACF. Unidades de maza para ruedas

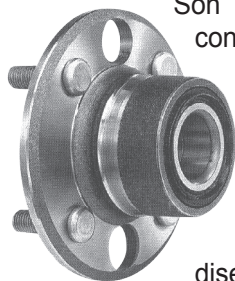

Son unidades de rodamientos de bolas con contacto angular de doble hilera, que incorporan una brida para ruedas. Las siglas DACF provienen de su nombre en inglés (Double Angular Contact BB with Flange).

Son unidades de alta confiabilidad, diseño compacto y ligero. También son conocidas como unidades de cubo.

Entre sus ventajas podemos mencionar:

- Confiabilidad mejorada por la instalación de un sello-retenedor en el rodamiento.
- Control del rango de expansión del juego interno post-montaje a través de la reducción del ajuste del aro exterior; lográndose una extensión de la vida de servicio y un funcionamiento silencioso.
- Procedimiento simplificado de ensamble.
- Liviano y compacto con alta capacidad.

En resumen, con su juego interno preajustado, diseño pre-lubricado y sellado, con un número reducido de componentes, se traduce en un ahorro total de costos y mayores beneficios.

Dentro de la serie DACF, se distingue la segunda generación (DACF1000, aro externo en forma de brida), la tercera generación (DACF2000, aro interno y externo extendidos en forma especial y de brida) y las unidades de cubo con sensor ABS integrado.

La tendencia actual en el uso de estas unidades para ruedas es:

DAC ó DACF2000 para ruedas motoras / DACF1000 + Unidades con sensor ABS para ruedas movidas.

Serie DU..., DUF... Unidades con rodamientos de rodillos cónicos para ruedas

Las series DU..., y DUF... se componen de rodamientos de rodillos cónicos de doble hilera en posición espalda-espalda, y de un rodamiento de rodillos cónicos de doble hilera con brida ("F" de Flange) incorporada, respectivamente.

Serie DU...

Es una unidad desarrollada a partir de un rodamiento tipo TDO de rodillos cónicos en diseño abierto (tipo 46T...) Posteriormente se añadió el sello (retenes) similar a las unidades DAC...

Al igual que en los rodamientos de bolas con contacto angular (DAC) la serie DU de rodillos cónicos se conoce como la primera generación, posterior al uso de dos rodamientos de una hilera de rodillos cónicos individuales.

Serie DUF...

Dentro de la serie DUF..., se distingue: la segunda generación (DUF1000), que se trata de un diseño de unidad DU con copa doble extendida que se conforma en una brida. Esta segunda generación es usada normalmente en ruedas movidas.

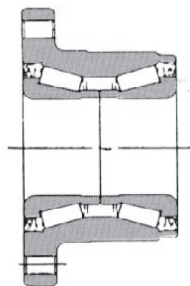

DUF1000 - 2da. Generación. (Rueda motriz, rotación del aro interno)

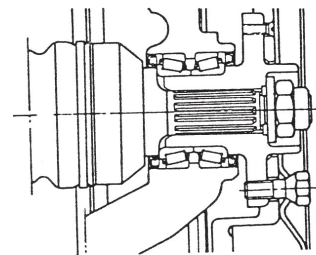

DUF2000 - 3era. Generación. (Rueda motriz)

La tercera generación es la serie DUF2000, que es una combinación de la segunda generación con un cubo (maza) acoplado al aro interno. La parte interna del cubo (maza) lleva unas estrías fresadas para ruedas motrices.

Gracias a sus sellos en ambos lados, a todas las unidades se les aplica grasa desde su armado previniendo así la pérdida de grasa y la entrada de agua y suciedades.

▶▶ RODAMIENTOS AUTOMOTRICES

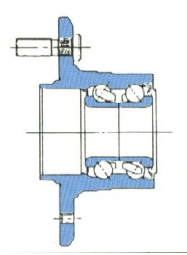
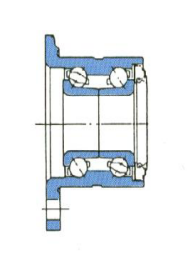
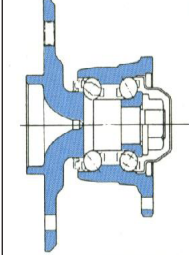
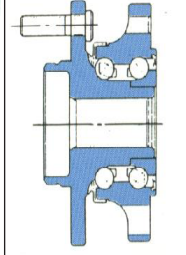
Estructura					
Tipo		Segunda Generación (DACF1000)		Tercera Generación (DACF2000)	
Rueda aplicada	Motriz				•
	Movida	•	•	•	
Rotación	Aro Interior		•	•	•
	Aro Exterior	•			

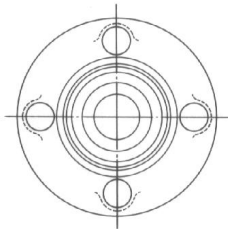

Tipo A

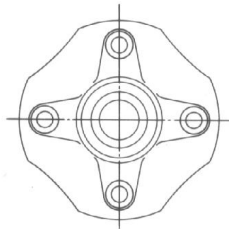



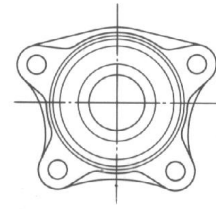











Tipo B



Tipo C

Forma del Borde











Rodamientos DAC... de doble hilera de bolas con contacto angular para ruedas y otras aplicaciones

Designación	Foto	N° parte (O.E.M)	Fabricante/Modelo	Aplicación	Observación	Dimensiones básicas (mm)			
						d	D	B (a.int.)	C (a.ext.)
DAC164044 2RSLCS16		35820094	JOHN DEERE	Azadón rotativo	Obturación: 2 labios	16.00	40.00	44.00	39.00
DAC174021A 2RS		N/D	FORD	Tractor agrícola	•	17.00	40.00	21.00	•
DAC2258A1NRC3		8062-22030	SUBARU /Leone	Transmisión	Descontinuado	22.00	58.00	25.00	23.00
DAC2358NRC3		8062-23010	SUBARU	Transmisión	Cambio a DAC2358NSRSH2C3	23.50	58.00	27.00	•
DAC2358NSRSH2C3		8062-23010	SUBARU	Transmisión	•	23.50	58.00	27.00	•
DAC2552W-1 SH2CS25		46860-80G00	SUZUKI/Swift 1.3 lt	Rueda trasera	Cambio a DAC2552W-11SH2CS25	25.00	52.00	21 X 2	42.00
DAC2552W-11SH2CS25		46860-80G00	SUZUKI/Swift 1.3 lt	Rueda trasera		25.00	52.00	21 X 2	42.00
DAC2552W-13CS25		44130-4A00A	SUZUKI ALTO/MARUTI	Rueda trasera	•	25.00	52.00	21 X 2	42.00
DAC2552W-7CS31		N/D	ATV KAWASAKI	Rueda	•	25.00	52.00	42.00	42.00
DAC2565-1NSR1C3		8062-27010	SUBARU/Impreza	Transmisión	Antes DAC2565NRC3	25.50	65.00	31.00	•
DAC276050ZRS		43210-61A00	NISSAN /Sentra	Rueda trasera	•	27.00	60.00	50.00	•
DAC2858 2RKCS47		09267-28001	SUZUKI/Carry	Rueda delantera	•	28.00	58.00	42.00	42.00
DAC2858 2RKCS47		09267 39005	DAEWOO/ Espero	Rueda delantera	•	28.00	58.00	42.00	42.00
DAC286142AW CS40		90369-28005(6)	TOYOTA/Corolla, Tercel	Rueda trasera	•	28.00	61.00	42.00	42.00
DAC286142AW CS40		94840382	CHEVROLET	Eje trasero	•	28.00	61.00	42.00	42.00
DAC295523-1SH2CS25		N/D	DAIHATSU/Storia	Compresor A/A	Descontinuado	29.00	55.00	22.50	22.50
DAC3052-3 2RR9DS1CS35		N/D	NIPPON DENSO	Embrague elec- mag.A/A	Exclusivo/ Restricción para venta	30.00	52.00	22.00	22.00
DAC3055-42RR9DS1CS35		N/D	HYUNDAI	Aire Acondicionado	•	30.00	55.00	23.00	23.00
DAC3055C 2RKCD3		N/D	NIPPON DENSO	Compresor A/A	Sello RK de silicon	30.00	55.00	26.00	•
DAC3055W-3CS31		51529-31G00	SUZUKI	Rueda	•	30.00	55.00	32.00	•
DAC3060W-1 CS78		5937306	FIAT (Uno)	Rueda delantera	Descontinuado	30.00	60.03	37.00	37.00
DAC3062WCS9		MR453133	MITSUBISHI (T.Box)	Rueda trasera	•	30.00	62.00	•	•
DAC3063W-1 CS44		90369-30043(4)	TOYOTA/Celica, Carina,Corona,Camry	Rueda trasera	Antes DAC3063WCS55	30.00	63.00	42.00	•
DAC3064W 2RKBCS28		43462-77501	SUZUKI	Rueda movida	•	30.00	64.00	21.00 X 2	42.00
DAC3267W CS35		42300-S2L-004	HONDA (HRV 4X4)	Rueda trasera	Cambio a DAC3267W-2CS35	32.00	67.00	40.00	•
DAC3267W-2CS35		42300-S2L-004	HONDA (HRV 4X4)	Rueda trasera	•	32.00	67.00	40.00	•
DAC3464W-5 2RSCS44		09267-34001	SUZUKI	Rueda movida	Antes...DAC3464W-42RSCS37	34.00	64.00	37.00	•
DAC3464W-5 2RSCS44		N/D	DAEWOO/ Cielo	Rueda delantera	Equivalente B35 (BCA)	34.00	64.00	37.00	•



















Rodamientos DAC... de doble hilera de bolas con contacto angular para ruedas y otras aplicaciones

Designación	Foto	N° parte (O.E.M)	Fabricante/Modelo	Aplicación	Observación	Dimensiones básicas (mm)			
						d	D	B (a.int.)	C (a.ext.)
DAC3464W-5 2RSCS44		44300-SB2-014 (44300-SB2-018)	HONDA/Acty, (Civic 1.6 lt.)	Rueda delantera (Rueda trasera)	•	34.00	64.00	37.00	•
DAC3468 2RSCS53		42300-SD4-004	HONDA/Legend	Rueda trasera	•	34.00	68.00	42.00	42.00
DAC3468 2RSCS53		8-94464-637	ISUZU/ Gemini	Rueda delantera	•	34.00	68.00	42.00	42.00
DAC355020 2RD3-1XSZ		N/D	SANDEN	Magnetic Clutch	•	35.00	50.00	20.00	20.00
DAC355020 2RD3XCS21		N/D	SANDEN	Compresor A/A	Cambio a DAC355020 2RD3-1XSZ	35.00	50.00	20.00	20.00
DAC355220 2RR9XCS32		N/D	FIAT /Punto	Embrague elec- mag.A/A	•	35.00	52.00	20.00	20.00
DAC35552RD3XS1CS33		85430020	SANDEN	Sist. Aire Acondicionado	Antes 83A694CS30	35.00	55.00	20.00	20.00
DAC3562AW-1CS35		09267-35003	SUZUKI/ Baleno,Cultus	Rueda trasera	•	35.00	61.80	31.00	31.00
DAC3562W-5CS35		43440-78A20	SUZUKI/Alto, Wagon	Rueda delantera	•	35.00	61.80	40.00	40.00
DAC3564A-1CS31		90043-63150	DAIHATSU/ Charade,Gran Move (DAIHATSU/ Atrai,Charade 1.0 lt)	Rueda trasera (Rueda delantera)	Antes DAC3564A-1CS45	35.00	64.00	37.00	37.00
DAC3564W-18CS35		90043-63320	DAIHATSU CHARADE (MIRA)	Rueda delantera	•	35.00	64.00	37.00	37.00
DAC3568W-6CS81		90369-35029 (-35030)	TOYOTA /Starlet	Rueda delantera	•	34.99	68.02	16.5 X 2	30.00
DAC3568W-6CS81		40210-34B00 (-21B00)	NISSAN /March	Rueda delantera	•	34.99	68.02	16.5 X 2	30.00
DAC357227CCS7		29114-56E00	SUZUKI	Diferencial lat. (veh.4x4)	•	35.00	72.00	13.5 X 2	27.00
DAC357227CCS7		N/D	CITROEN	Rueda delantera	•	35.00	72.00	13.5 X 2	27.00
DAC357229BCS		MD703730	MITSUBISHI/Galant	Transmisión	Descontinuado	•	•	•	•
DAC357233B-1WCS79		90363-35015 (-35016)	TOYOTA/Tercel ('86),Corolla	Rueda delantera	•	35.00	72.02	33.00	31.00
DAC357234ACS20		91051-634-004	HONDA/ Accord	Rueda delantera	•	35.00	72.00	34.00	34.00
DAC357234ACS20		91051-692-003 (004)	HONDA / Quintet	Rueda delantera	•	35.00	72.00	34.00	34.00
DAC357245CW2RS		90363-35001 (-35101)	TOYOTA/ Corolla	Rueda trasera	•	35.00	72.00	22.5 X 2	45.00
DAC357245CW2RS+C014		04421-14010	TOYOTA/ Corolla 1.6 lt.	Rueda trasera	•	35.00	72.00	22.5 X 2	45.00















Rodamientos DAC... de doble hilera de bolas con contacto angular para ruedas y otras aplicaciones

Designación	Foto	N° parte (O.E.M)	Fabricante/Modelo	Aplicación	Observación	Dimensiones básicas (mm)			
						d	D	B (a.int.)	C (a.ext.)
DAC3577W-3CS80		90369-35034	TOYOTA/Lexus 400, Supra	Rueda delantera	•	34.99	77.04	21 X 2	42.00
DAC3577W-3CS80		90369-63006	TOYOTA/ Lexus 401, Crown	Rueda delantera	•	34.99	77.04	21 X 2	42.00
DAC3580WHR4CS0		90369-35060	TOYOTA/Lite Ace, Estima, Previa	Rueda trasera	•	35.00	80.00	23.5 X 2	47.00
DAC358047BW2RS		90363-35087	TOYOTA / Corona	Rueda trasera	•	35.00	80.00	23.5 X 2	47.00
DAC3665WCS30		43462-50F00	SUZUKI / Every, Carry	Rueda delantera	•	36.00	65.00	18.5 X 2	37.00
DAC3668AWCS36		09267-36002	SUZUKI / Cultus, Swift	Rueda delantera	Radio de bisel, r=3.0	36.00	68.00	33.00	33.00
DAC3668WCS36		09267-36001	SUZUKI / Cultus, Swift	Rueda delantera	Radio de bisel, r=1.5	36.00	68.00	33.00	33.00
DAC3768W-3CS11		MR410569	MITSUBISHI/ Montero(Pajero)	Rueda trasera	Anillo ret. Antes DAC3768W-2CS11	37.00	68.00	34.00	34.00
DAC3870BWCS41		90043-68187	DAIHATSU	Rueda delantera	•	38.00	70.00	38.00	38.00
DAC3870W-3CS22		90043-63213	DAIHATSU/Applause, Charade, Terios	Rueda delantera	Cambio a DAC3870W-7CS66	38.00	70.00	19.00x2	38.00
DAC3870W-5CS66		90043-63314	DAIHATSU	Rueda	Cambio a DAC3870W-7CS66	38.00	70.00	19.00x2	38.00
DAC3870W-6CS66		90043-63369	DAIHATSU TERIOS	Rueda delantera	Antes DAC3870W-4CS66	38.00	70.00	19.00x2	38.00
DAC3870W-7CS66		90043-63314	DAIHATSU	Rueda	Antes DAC3870W-5CS66 (3CS22)	38.00	70.00	19.00x2	38.00
DAC3871W-2CS70		90369-38006	TOYOTA/Corolla, Tercel ('90-'94)	Rueda delantera	•	37.99	71.02	16.50x2	30.00
DAC3871W-3CS63		90369-38021/38022	TOYOTA/ Yaris 1.3 lt. (2000)	Rueda delantera	•	38.00	71.00	39.00	39.00
DAC3872ACS42		91051-SB0-004	HONDA/Accord-USA, Prelude	Rueda delantera	•	38.00	72.00	17.00x2	34.00
DAC3872B12RSCS42		44300-SX8-004	HONDA	Rueda delantera	Cambio a DAC3872W-10CS42	38.00	72.00	20.00 X 2	40.00
DAC3872W-10CS42		44300-SX8-004	HONDA/Civic 1.6 lt.	Rueda delantera	Radio de bisel, r=3.0	38.00	72.00	20.00 X 2	40.00
DAC3872W-10CS42		44300-SB2-962	HONDA/Civic 1.3 -1.6 lt., CR-X	Rueda delantera	Radio de bisel, r=3.0	38.00	72.00	20.00 X 2	40.00
DAC3872W-8CS81		90369-38011	TOYOTA/Corolla 1.6 lt, Sprinter	Rueda delantera	Antes DAC3872W-3CS72	37.99	72.02	18 X 2	33.00
DAC3873W-2CS71		44300-S04-004	HONDA/Civic 1.5 lt, CR-X	Rueda delantera	Placa Z un lado SelloRS otro lado	38.00	73.00	40.00	•
DAC3873WCS53		44300-S04-004	HONDA	Rueda delantera	Use.DAC3873W-2CS71	38.00	73.00	40.00	•



Rodamientos DAC... de doble hilera de bolas con contacto angular para ruedas y otras aplicaciones

Designación	Foto	Nº parte (O.E.M)	Fabricante/Modelo	Aplicación	Observación	Dimensiones básicas (mm)			
						d	D	B (a.int.)	C (a.ext.)
DAC3874W-6CS84		90369-38002	TOYOTA/RAV4, Caldina ('97)	Rueda delantera / Rueda tras. (Caldina)	También p/ Nissan Sentra (Tsuru III) Rueda del.	37.99	74.02	18 X 2	33.00
DAC3874W-6CS84		90369-38003	TOYOTA / Carina, Corona	Rueda delantera		37.99	74.02	18 X 2	33.00
DAC387436W		N/D	CHEVROLET / Nova	Rueda trasera	Descontinuado	38.00	74.00	36.00	•
DAC3880W-1CS65		90903-64002	TOYOTA/Caldina	Rueda delantera	•	37.97	80.02	18 X 2	33.00
DAC3972AW4CS49		8-94254-352	ISUZU	Rueda delantera	•	39.00	72.00	37.00	37.00
DAC3972AW4CS49		N/D	CHEVROLET	Rueda delantera	•	39.00	72.00	37.00	37.00
DAC4062242RD3H1CS45		9396-0020S	SANDEN	Compresor A/A	•	40.00	62.00	24.00	24.00
DAC407043WCS83		MB663547	MITSUBISHI/ Lancer, Mirage	Rueda trasera	•	40.00	70.00	43.00	43.00
DAC4072W-3CS35		09267-40001	SUZUKI/ Baleno	Rueda delantera	•	40.00	72.00	18 X 2	36.00
DAC4072W-10CS74		43440-54G01	SUZUKI/ Aerio	Rueda delantera	Nºválido en aro ext.	39.99	72.08	36.00	36.00
DAC4074CWCS73		MB808442	MITSUBISHI/ Montero(Pajero)	Rueda delantera	También p/ Carisma	40.00	74.00	18 X 2	34.00
DAC4074W-3CS80		90363-40066	TOYOTA/Celica, Corolla	Rueda delantera	•	40.00	74.00	21 X 2	42.00
DAC4074W-6CS61		MR519097	MITSUBISHI/Lancer	Rueda delantera	Sellos ZZ,2 lados	40.00	74.00	36.00	36.00
DAC4074W-7CS9		43591-52D00	SUZUKI/Grand Escudo	Rueda trasera	Sello en un lado solamente	40.00	74.00	18 X 2	36.00
DAC4074W-12CS47		Antes DAC407440CS77	MAZDA 323	Rueda delantera	Sello metálico hacia lado int.	40.00	74.00	20x2	40.00
DAC407440CS77		B455-33-047	MAZDA 323 /Familia-Ford/Laser	Rueda delantera	Cambio a DAC4074W-12CS47	40.00	74.00	20x2	40.00
DAC4075W-2CS73		90363-40080	TOYOTA/Yaris	Rueda Frontal	•	40.00	75.00	39.00	39.00
DAC4076412RSCS42		44300-SEO-003	HONDA Accord	Rueda delantera	También... 44300-SEO-004	40.00	76.00	41.00	38.00
DAC4080M1CS68		MB303865	MITSUBISHI/Diamante, Lancer, Galant	Rueda delantera	•	40.00	80.00	18 X 2	34.00
DAC4168WCS23		Cambio a DAC4168WHR4CS23	SUZUKI	Rueda delantera	•	41.00	68.00	20 X 2	35.00
DAC4168WHR4CS23		09267-41001	SUZUKI / Samurai,Vitara	Rueda delantera	•	41.00	68.00	20.00 x 2	35.00
DAC4275W-4CS79		N/D	BMW /PL2/E90	Ruedas	Descontinuado	42.00	75.00	37.00	37.00
DAC4275BW 2RSCS59		N/D	BMW /E46	Ruedas	Descontinuado	42.00	75.00	37.00	37.00
DAC4276402RSCS55		N/D	CHRYSLER	Rueda delantera	Radio de bisel, r=3.5	42.00	76.00	20.00 x 2	37.00
DAC4278A2RSCS52		44300-SD4-000,-004	HONDA	Rueda delantera	•	42.00	78.00	38.00	38.00

Rodamientos DAC... de doble hilera de bolas con contacto angular para ruedas y otras aplicaciones

Designación	Foto	N° parte (O.E.M)	Fabricante/Modelo	Aplicación	Observación	Dimensiones básicas (mm)			
						d	D	B (a.int.)	C (a.ext.)
DAC4278C2RSCS40		44300-SF1-008	HONDA/Acura, Prelude,CR-X	Rueda delantera	•	42.00	78.00	41.00	38.00
DAC4280B 2RSCS87		N/D	BMW / E-28	Rueda trasera	Descontinuado	42.00	80.00	42.00	42.00
DAC4280W-2CS40		GA2A-33-047	MAZDA / 626('91-'94), Capella	Rueda delantera	Cambio a DAC4280W-2ACS40	42.00	80.00	22.5 x 2	45.00
DAC4280W-2ACS40		GA2A-33-047	MAZDA / 626('91-'94), Capella	Rueda delantera	Antes DAC4280W-2CS40	42.00	80.00	22.5 x 2	45.00
DAC4280W-5CS38		N/D	JAGUAR /S-Type	Ruedas	•	42.00	80.02	45.00	45.00
DAC4379WCS64		44300-S04-A02	HONDA/Civic, Integra, CR-X	Rueda delantera	Cambio a DAC4379W-1CS57	43.00	79.00	41.00	38.00
DAC4379W-1CS57		44300-S04-A02	HONDA/Civic, Integra, CR-X	Rueda delantera	Antes DAC4379WCS64	43.00	79.00	41.00	38.00
DAC4380ACS69		90369-43005	TOYOTA/Cressida, Crown,MarkII-Lexus	Rueda trasera	•	43.00	80.00	25 X 2	45.00
DAC4382W-3CS79		90369-43008	TOYOTA/Camry, Crown,Cressida	Rueda delantera	•	43.00	82.00	45.00	45.00
DAC4382W-3CS79		90369-43009	TOYOTA/RAV4-Lexus 300	Rueda delantera	•	43.00	82.00	45.00	45.00
DAC4484B2RSCS69		44300-SSO-014	HONDA/Prelude('91-'94)	Rueda delantera	Cambio a DAC4484CW2RSCS76	44.00	84.00	42.00	42.00
DAC4484CW2RSCS76		44300-SSO-014	HONDA/Prelude('91-'94)	Rueda delantera	Antes DAC4484B2RSCS69	44.00	84.00	42.00	42.00
DAC4580W-2CS66		F151-26-151A	MAZDA	Rueda Trasera	•	45.00	80.00	25 X 2	50.00
DAC4583CS62		J001-26-151	MAZDA/ Mod.929/RX7	Rueda trasera	•	45.00	83.00	45.00	45.00
DAC4583CS62		J001-26-152	MAZDA/Eunos 2.3 lt.	Rueda delantera	•	45.00	83.00	45.00	45.00
DAC4584DWCS76		MB633430	MITSUBISHI/Diamante, Sigma, RVR	Rueda delantera	Sellos de caucho RS en ambos lados	45.00	84.00	41.00	39.00
DAC4584W-1CS81		90369-45003	TOYOTA/ Highlander/ Camry	Rueda delantera	Placas met. ZZ	45.00	84.00	22.5 X 2	45.00
DAC4586WCS69		90369-45006	TOYORA / Highlander/ Lexus	Rueda delantera	•	45.00	86.00	45.00	45.00
DAC4781WSH2CS56		F.Mogul 510028	NISSAN /Quest	Rueda delantera	•	47.00	81.00	53.00	53.00
DAC4889W-1CS16		90369-48001	TOYOTA/Land Cruiser('98)	Rueda trasera	Biseles, r=1.0/3.5,0.8	48.00	89.00	22.0 X 2	42.00
DAC4889W2RSCS94		44300-SPO-004,-008	HONDA-Acura/Legend	Rueda delantera	Biseles, r=1.0/3.0	48.00	89.00	44.00	42.00
DAC4984WCS71		90369-49001,-49002	TOYOTA/Crown, Mark II (Lexus)	Rueda trasera	•	49.00	84.00	25x2	50.00

Rodamientos DU... Doble hilera de rodillos cónicos para ruedas

Designación	Foto	Nº parte (O.E.M)	Fabricante/Modelo	Aplicación	Observación	Dimensiones básicas (mm)			
						d	D	B (a.int.)	C (a.ext.)
HCDU2753LFTCS43		N/D	GM	Rueda trasera	Unidada con sello	27.00	53.00	43.00	43.00
HCDU2753LFTCS43		N/D	OPEL (New Corsa)	Rueda trasera	Unidad con sello	27.00	53.00	43.00	43.00
HI-CAPDU3868CS39		8-94464-638	ISUZU / Gemini	Rueda delantera	Descontinuado	38.00	68.00	37.00	•
HI-CAPDU4080		90369-40003	TOYOTA /Land Cruiser	Rueda trasera	•	40.00	80.00	44.00	44.00
HCDU4788-2LFT		90369-47001	TOYOTA/Granvia 3.0 lt	Rueda trasera	•	47.00	88.00	28.75	•
HCDU5496-5LFT		90369-54001	TOYOTA (Hi Lux, L.Cruiser, Sequoia)	Rueda delantera	Cambio a HCDU5496-6LFT	54.00	96.00	25.5 X 2	51.00
HCDU5496-6LFT		90369-54001	TOYOTA (Hi Lux, L.Cruiser, Sequoia)	Rueda delantera	SOLO RODAMIENTO (Antes HCDU5496-5LFT)	54.00	96.00	25.5 X 2	51.00
DU60108-8CS40		N/D	DAIMLER-CHRYSLER/ Camión	Rueda delantera	Descontinuado	60.00	108.00	75.00	75.00

▶ RODAMIENTOS AUTOMOTRICES

SERIE DAC

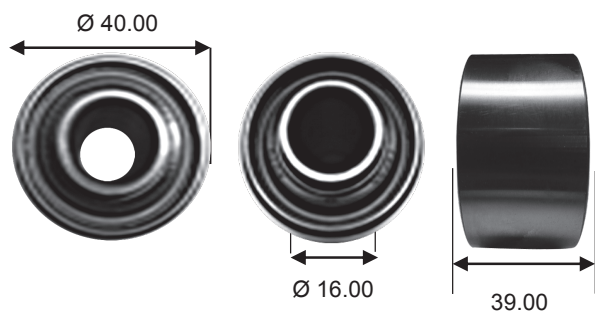

DAC1640442RSLCS16

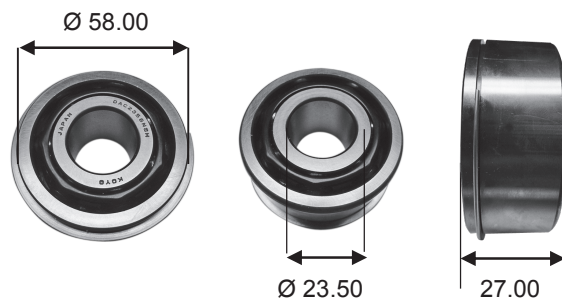

DAC2358NSRSH2C3

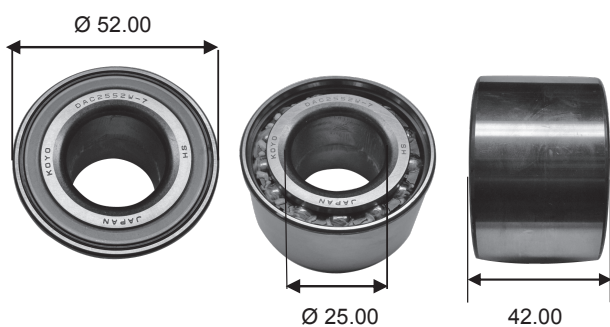

DAC2552W - 11SH2CS25

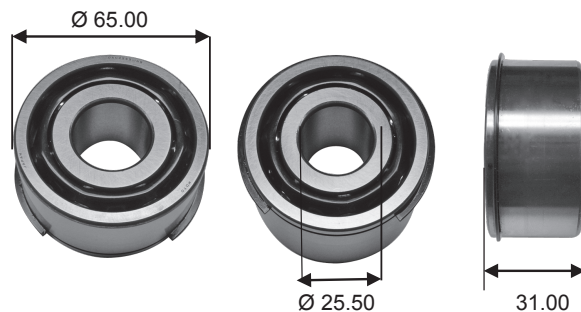

DAC2565 - 1NSR1C3

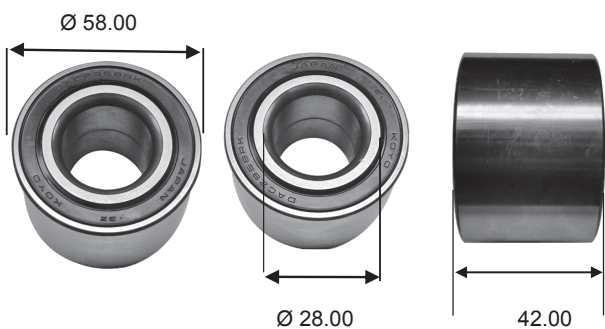

DAC28582RKCS47

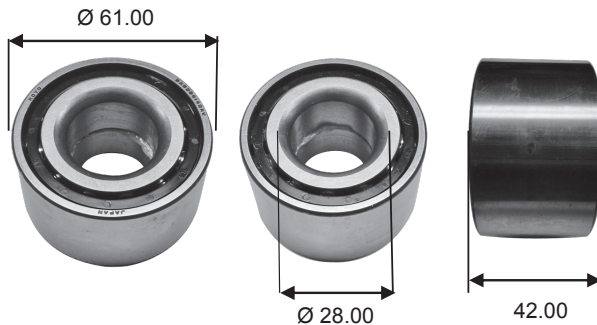

DAC286142AWCS40

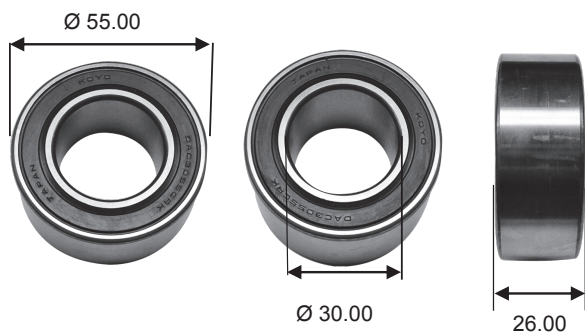

DAC3055C2RKCD3

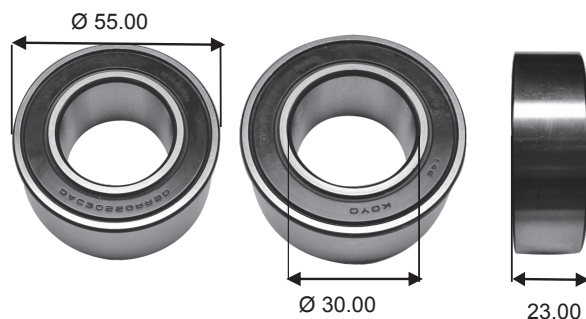

DAC3055 - 42RR9DS1CS21

▶ RODAMIENTOS AUTOMOTRICES

SERIE DAC

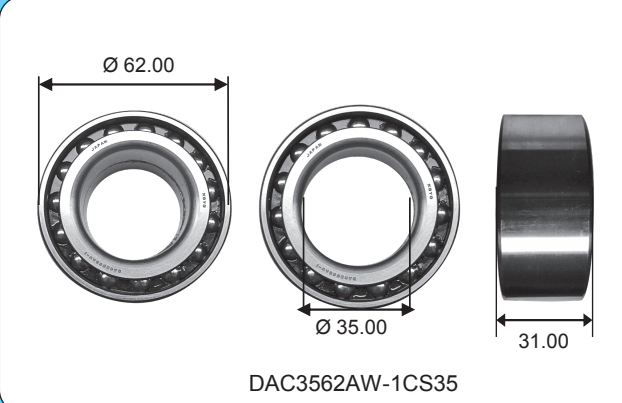
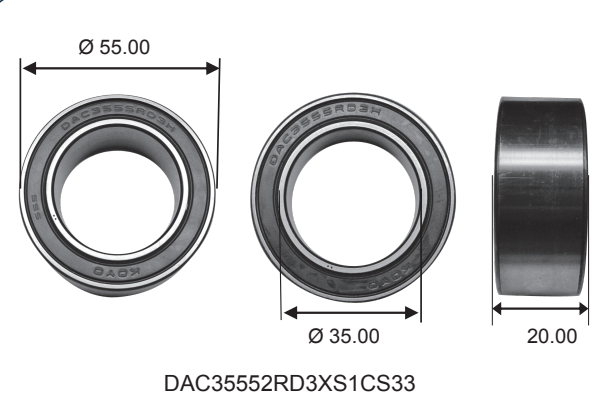
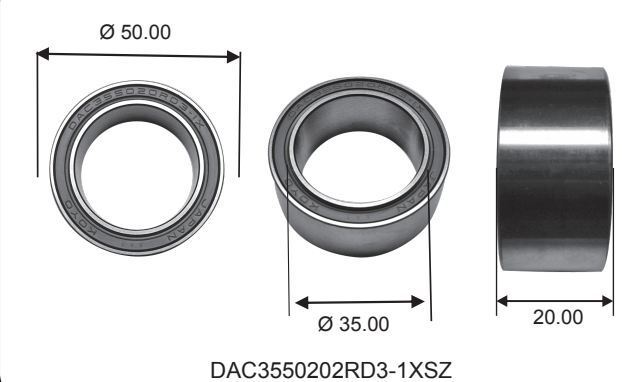
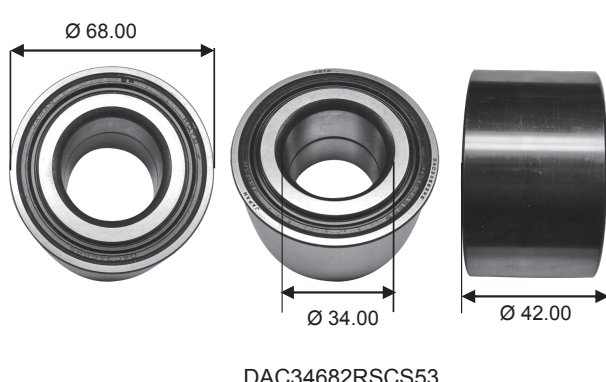
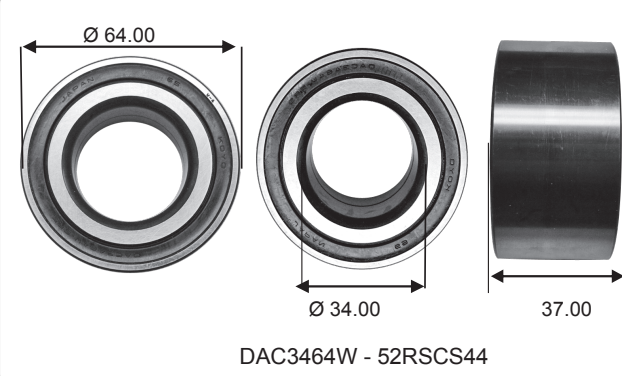
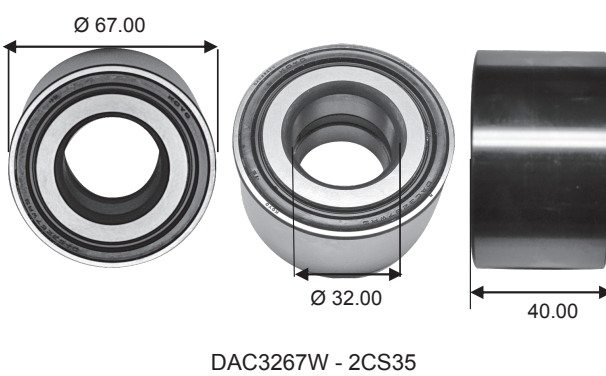
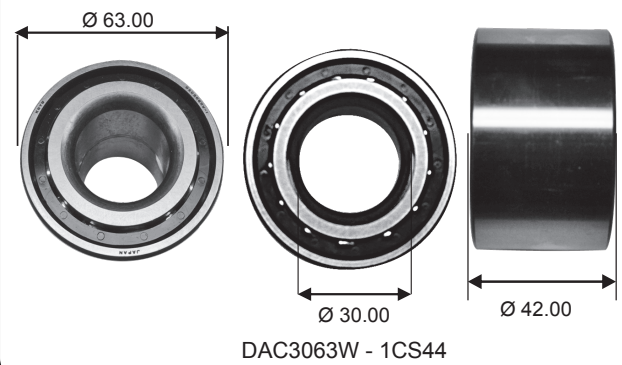
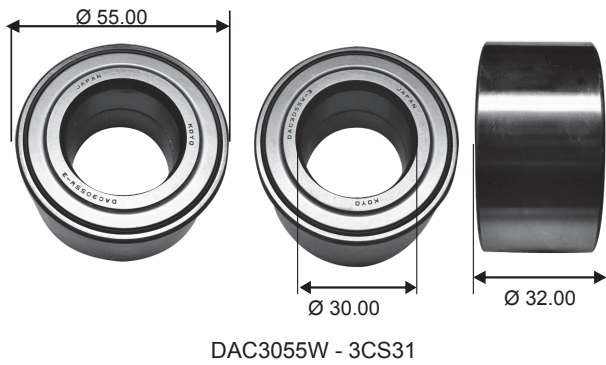

▶ RODAMIENTOS AUTOMOTRICES

SERIE DAC

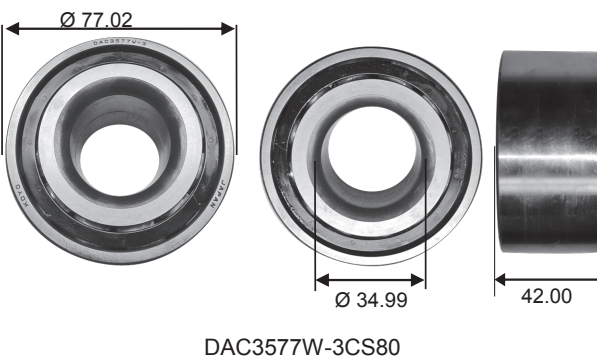
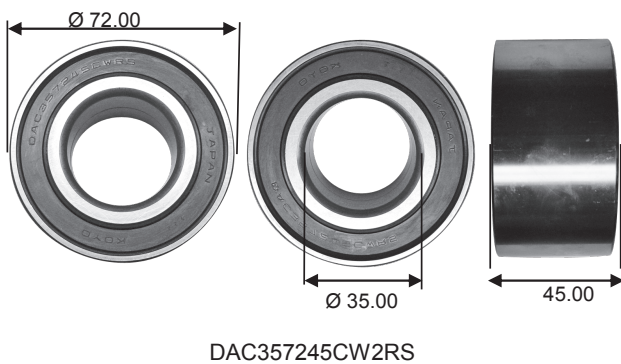
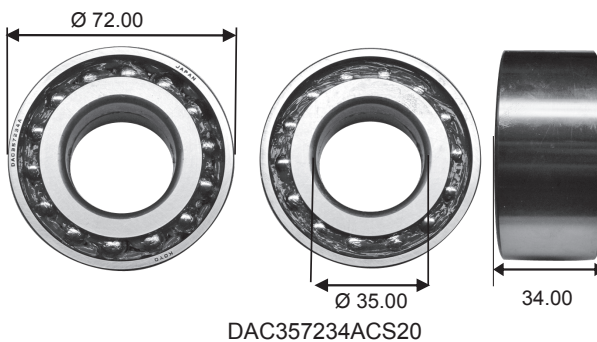
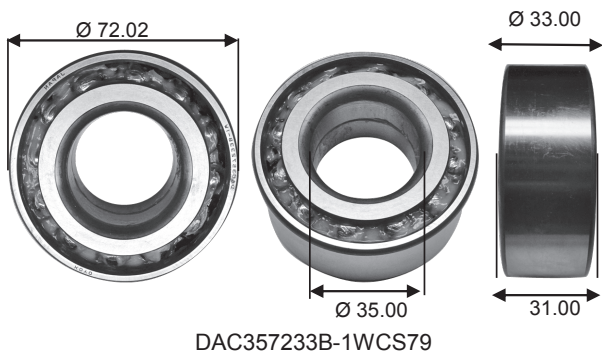
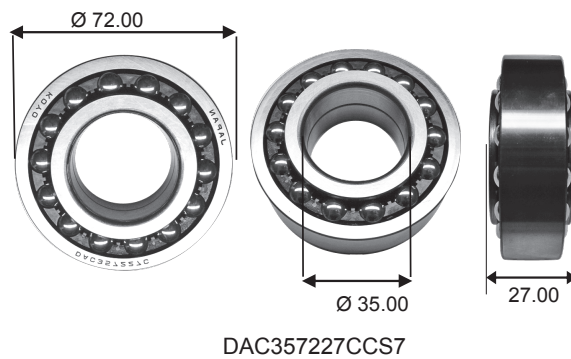
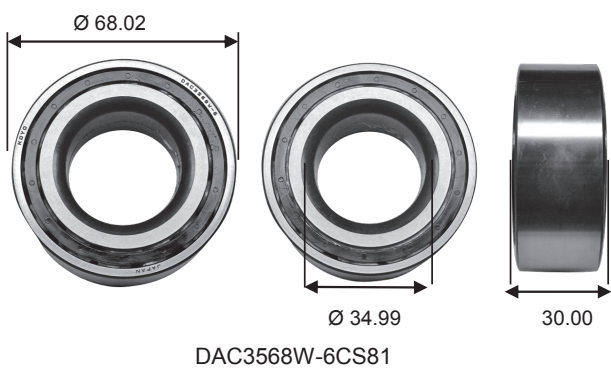
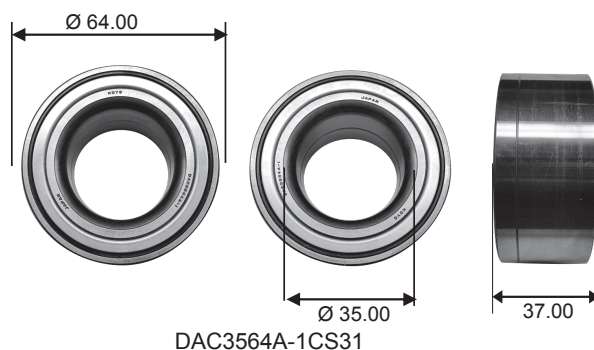
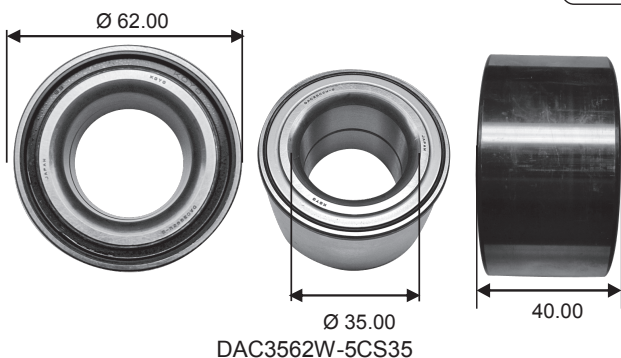

▶ RODAMIENTOS AUTOMOTRICES

SERIE DAC

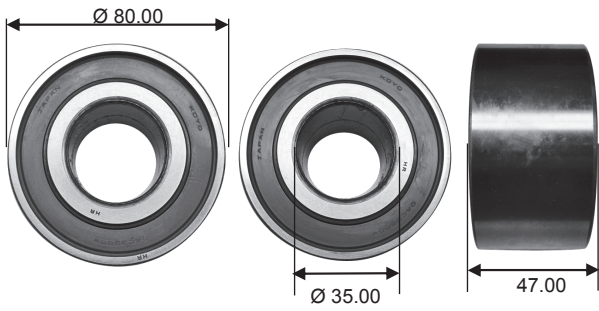

DAC3580WHR4CS0

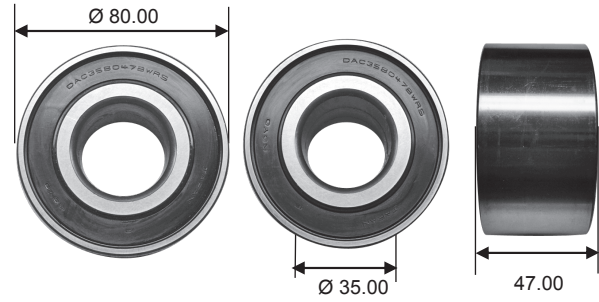

DAC358047BW2RS

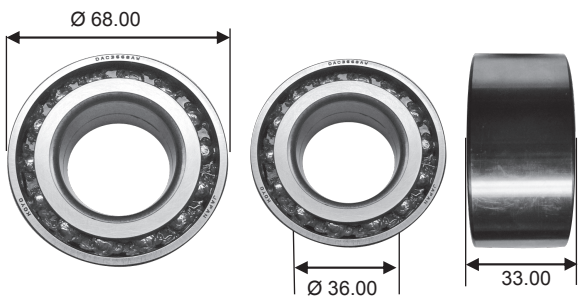

DAC3668AWCS36

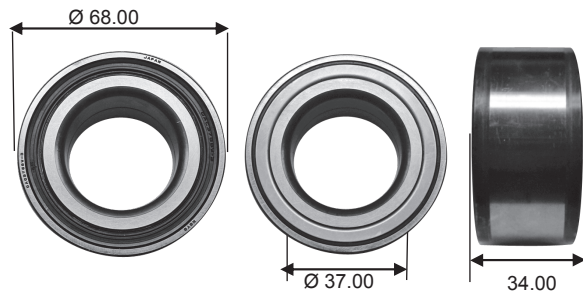

DAC3768W-3CS11

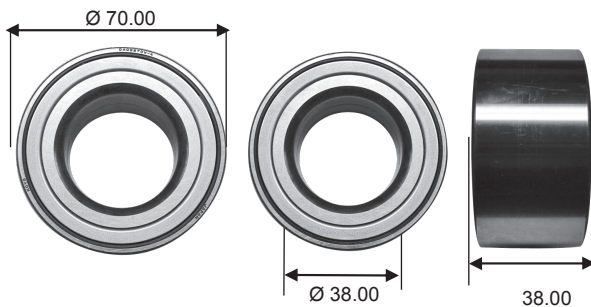

DAC3870W-5CS66

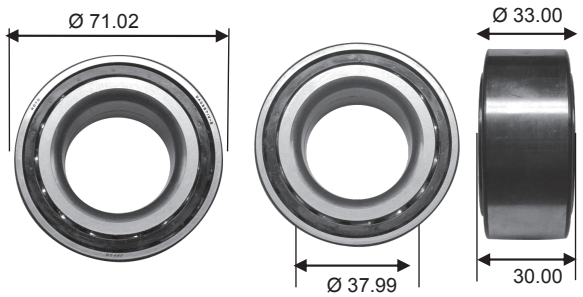

DAC3871W-2CS70

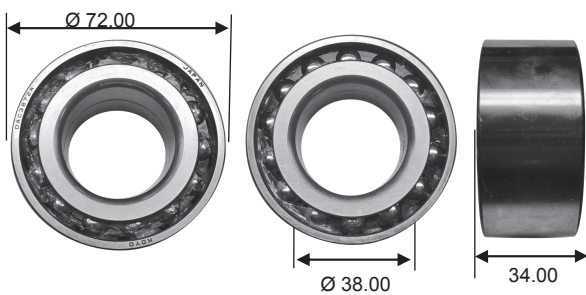

DAC3872ACS42

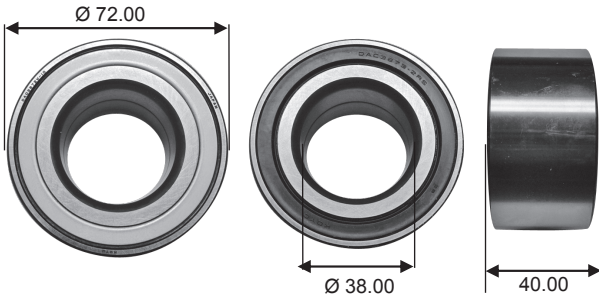

DAC3872W-10CS42

▶ RODAMIENTOS AUTOMOTRICES

SERIE DAC

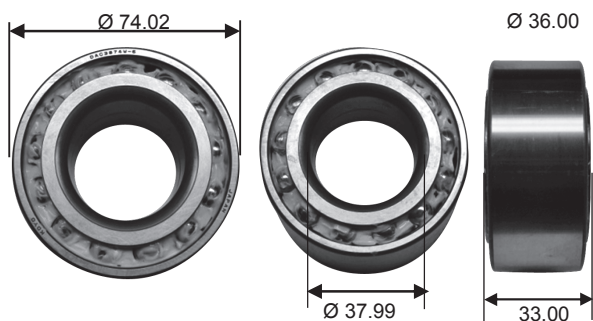

DAC3874W-6CS84

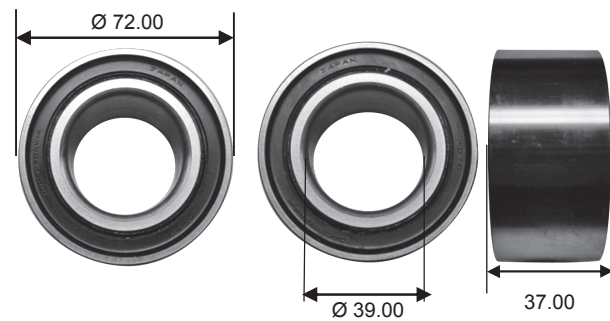

DAC3972AW4CS49

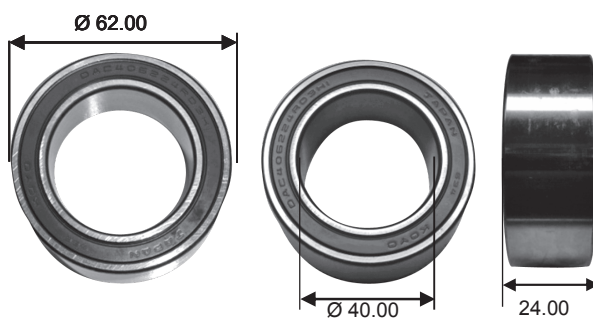

DAC4062242RD3H1CS45

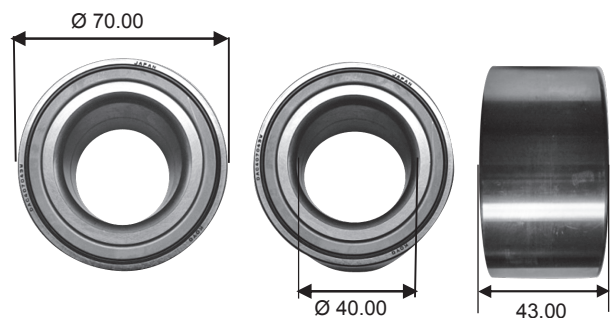

DAC407043WCS83

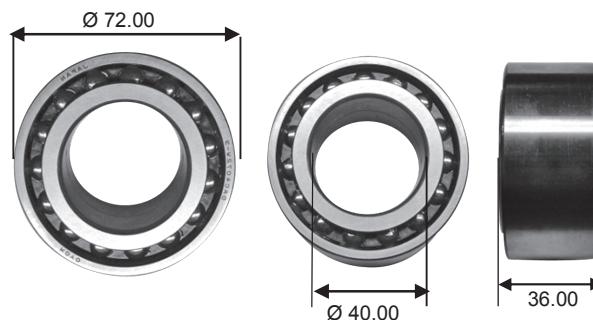

DAC4072W-3CS35

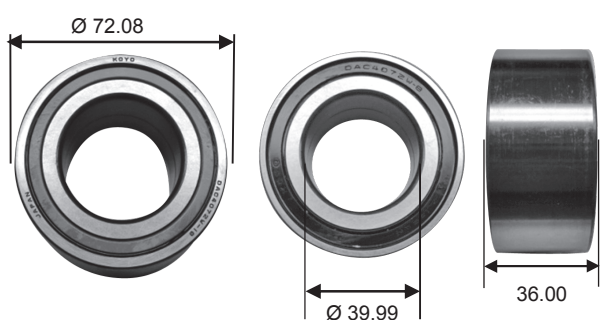

DAC4072W-10CS74

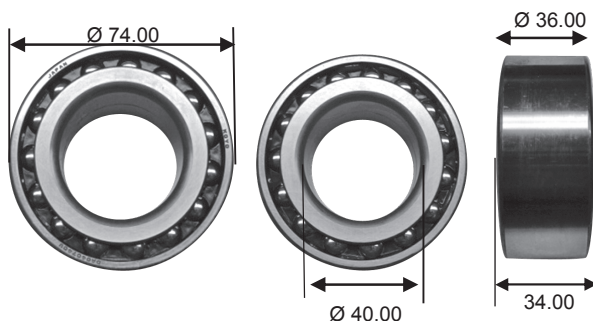

DAC4074CWCS73

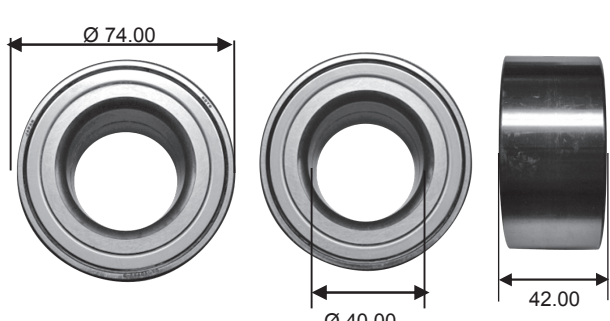

DAC4074W-3CS80

DAC-DACF-DU-DUF