

Koyo

Indice

SERIES DG..., DDG... RODAMIENTOS RÍGIDOS DE UNA O DOS HILERAS DE BOLAS

RODAMIENTOS AUTOMOTRICES

Series DG..., DDG... Rodamientos rígidos de una o dos hileras de bolas

Los rodamientos de la series DG..., y DDG... son rígidos de una y dos hileras de bolas, respectivamente. Tienen dimensiones no estándares y su diámetro interno es menor de 100 mm ($d < 100\text{mm}$). Por lo general, son rodamientos obturados y cuentan con características mejoradas por los tratamientos que se le aplican a sus componentes (aros y/o bolas), grasa especial, modificación del diseño externo (ranuras), sellos especiales, etc.



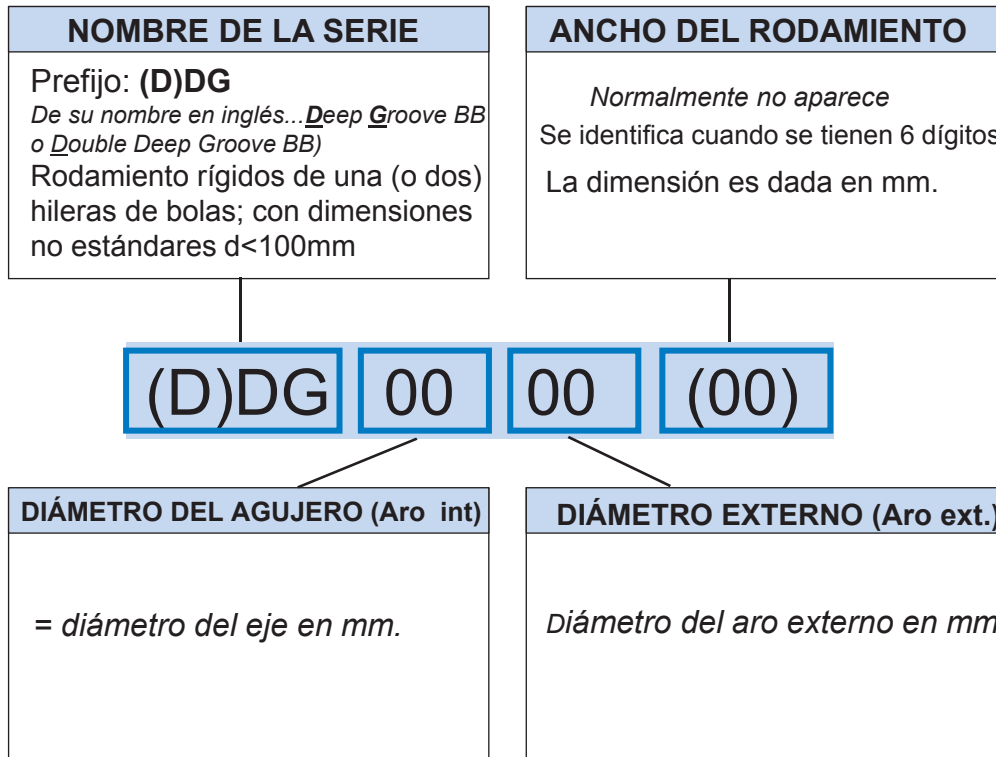



SISTEMA KOYO DE DESIGNACIÓN









Ejemplos:

DG2554A2RR1HCS12	Tensor de toyota Mark II	$d=25, D=54$ mm; sello esp. 2RR1 acero cementado (H), juego int. especial (CS de 12 umm)
DG409026W2RSHR4SH2C4	Rueda, Isuzu	$d=40, D=90, B=26$ mm; para ruedas (W), sello RS, acero altamente refinado (HR4), trat. térm. en a.i, juego C4
DDG15382RDH1CM	Montacarga Komatsu	$d=15, D=38, B=19$ mm; sello RD, juego especial CM.













Rodamientos rígidos de bolas de 1 ó 2 hileras -series DG, DDG- para diversas aplicaciones: ruedas, tensores y otras

Designación	Foto	Número de parte (O.E.M)	Fabricante	Aplicación	Dimensiones principales (unidad : mm)						Observación
					d	D	T ancho total	Bi ancho a.i.	Be ancho a.e.	B1, B ancho/ménsula	
Serie DG.....											
DG0823142RD1NYM4		N/D	Mitsubishi	Alternador (tras)	8.00	23.00	14.00	14.00	14.00	•	2 anillos nylon en a.e
DG082410		N/D	DAIHATSU	Equipo aux. motor	8.00	24.00	•	10.00	10.00	•	•
DG12582RD1HC2		N/D	YAMAHA	Tensor	12.00	57.60	•	30.00	•	•	•
DG1331SH2C3		MD736846	MITSUBISHI	Transmisión Automática	13.00	31.00	•	7.00	7.00	•	•
DG162RSNSCS10		N/D	GENERAL ELECTRIC	LAVADORA	15.88	35.00	11.00	11.00	11.00	•	Ranura en a.e
DG1740-72RKBFS1CS22		91005-422-014	HONDA / HITACHI	Acople ventilador	17.00	40.00	12.00	12.00	12.00	•	•
DG1742RSC3		09262-17034	SUZUKI	Rueda Motocicleta	17.00	42.00	•	13.00	13.00	•	•
DG175216.....		N/D	NIPPON DENSO	Alternadores	17.00	52.00	16.00	•	•	•	Restricción de venta
DG1928ZCS31		N/D	DAIHATSU. Charade	Columna dirección	18.72	28.00	7.00	7.00	7.00	•	Ancho aros > normal
DG1934-1C2		26095289	DELPHI-BR	Columna dirección	18.72	33.80	7.00	7.00	7.00	•	•
DG1934-1C2		90363-18015	TOYOTA	Columna dirección	18.72	33.80	7.00	7.00	7.00	•	•
DG1935A		N/D	N/D	Columna dirección	19.03	35.00	7.00	7.00	•	•	•
DG1938AC3		90363-18038	TOYOTA	Columna dirección	18.72	38.00	•	10.00	10.00	•	•
DG1938AC3		MB166193	MITSUBISHI	Columna dirección	18.72	38.00	•	10.00	10.00	•	•
DG205212-2-9TCS24		91005-GWO-0130	HONDA	CIGÜEÑAL	20.00	52.00	12.00	12.00	12.00	•	Abierto. Aros+gruesos
DG2137C3		N/D	FORD-CONTOUR	Columna dirección (Pinón sup.)	20.66	37.00	11.80	6.80	11.80	•	Ancho a.e > ancho a.i
DG2256-22RKDHR4SHZ		MD739350	MITSUBISHI	Transmisión	22.00	56.00	•	16.00	16.00	•	•
DG2256SH2C3		MD703798	MITSUBISHI	TENSOR	22.00	56.00	•	16.00	16.00	•	•
DG2256YRNRSC3		90363-22002	TOYOTA	N/D	22.00	56.00	•	16.00	16.00	•	•
DG2260YRRSNXC3		90363-22005	TOYOTA	N/D	22.00	60.00	•	16.00	16.00	•	Descontinuado

Rodamientos rígidos de bolas de 1 ó 2 hileras -series DG, DDG- para diversas aplicaciones: ruedas, tensores y otras

Designación	Foto	Número de parte (O.E.M)	Fabricante	Aplicación	Dimensiones principales (unidad : mm)						Observación
					d	D	T ancho total	Bi ancho a.i.	Be ancho a.e.	B1. B ancho/ ménsula	
DG2263-12RKMDSH2C4		90363-22007	TOYOTA	Transmisión	22.00	63.00	•	18.00	18.00	•	•
DG22682RK1HC3		N/D	N/D	Transmisión	22.00	68.00	•	18.00	18.00	•	Descontinuado
DG2450B2RKD1+SV		13505-10010	TOYOTA	TENSOR	25.00	50.00	•	26.50	37.50	•	•
DG2450C2RR1DCS16+SV		14510-PN4-004	HONDA	TENSOR	31.70	50.00	•	21.50	32.90	•	•
DG2550B-32RR1D		13503-11010	TOYOTA	TENSOR	25.00	50.00	•	28.50	27.00	•	•
DG2552K2RR1HC3+SV1		13505-70012	TOYOTA	TENSOR	25.00	52.00	•	30.10	35.00	•	•
DG2552K2RR1HC3+SV1		13505-70021	TOYOTA	TENSOR	25.00	52.00	•	30.10	35.00	•	•
DG2552K2RR1HC3+SV1		13505-70022	TOYOTA	TENSOR	25.00	52.00	•	30.10	35.00	•	•
DG2552K2RR1HC3+SV1		13505-88300	TOYOTA	TENSOR	25.00	52.00	•	30.10	35.00	•	•
DG2552K2RR1HC3+SV1		13505-88301	TOYOTA	TENSOR	25.00	52.00	•	30.10	35.00	•	•
DG2552J-2 2RKBFS12CS21		N/D	N/D	Embrague Ventilador	25.00	52.00	•	15.00	15.00	•	•
DG2552U2RKBFCFS19		N/D	NISSAN Serena	Diferencial	25.00	52.00	15.00	15.00	15.00	•	•
DG2554A2RR1HCS12+SV		13505-70030	TOYOTA	TENSOR	25.00	54.00	32.00	30.10	35.00	•	•
DG2554A2RR1HCS12+SV		13505-70040	TOYOTA	TENSOR	25.00	54.00	32.00	30.10	35.00	•	•
DG2554A2RR1HCS12+SV		13505-70010	TOYOTA	TENSOR	25.00	54.00	32.00	30.10	35.00	•	•
DG256318CS12		MD722948	MITSUBISHI	TENSOR	25.00	63.00	•	18.00	18.00	•	•
DG2568DNSH2C3		90363-25064	TOYOTA	TRANSMISIÓN	25.00	68.00	17.00	17.00	17.00	•	•
DG2568HNSH2C3		90363-25048	TOYOTA (Starlet)	TRANSMISIÓN	25.00	68.00	19.00	19.00	19.00	•	Ranura en a.e.
DG26522RR1C2+SV		N/D	MAZDA	TENSOR	26.00	52.00	26.00	19.50	54.50	•	•
DG26522RR1H+SV		F806-12-700A	MAZDA (Bongo)	TENSOR/Motor	26.00	52.00	•	27.00	32.50	•	•















Rodamientos rígidos de bolas de 1 ó 2 hileras -series DG, DDG- para diversas aplicaciones: ruedas, tensores y otras





Designación	Foto	Número de parte (O.E.M)	Fabricante	Aplicación	Dimensiones principales (unidad : mm)						Observación
					d	D	T ancho total	Bi ancho a.i.	Be ancho a.e.	B1, B ancho/ménsula	
DG26522RR1H+SV		F806-12-700	MAZDA (Bongo)	TENSOR/Motor	26.00	52.00	•	27.00	32.50	•	•
DG26522RR1H+SV		F806-12-700B	MAZDA (Bongo)	TENSOR/Motor	26.00	52.00	•	27.00	32.50	•	•
DG274712CS58		N/D	N/D	Caja de cambio	27.00	47.00	•	8.00	12.00	•	•
DG27552RR1DCS13+SV		14510-PJ7-003	HONDA (City 1.2lt, '86-'94)	TENSOR N°1	27.00	55.00	25.00	29.50	33.00	•	•
DG2755J2RR1DCS13+SV		14510-PJ7-013	HONDA (City 1.3lt, '88-'94)	TENSOR N°1	27.00	55.00	27.00	27.00	•	27.00	•
DG2852B82RR1H+SV1		13505-15041	TOYOTA (Sprinter)	Correa/Tiempo (Idler)	26.00	52.00	23.00	19.00	56.00	•	•
DG2883NS		N/D	N/D	Transmisión	28.00	82.50	•	23.00	23.00	•	•
DG30552RD1DCS28+SV		14510-PH1-004	HONDA (Accord,Prelude)	Tensor-Correa/tiempo	30.00	55.00	•	30.50	•	30.5 mang.	Manguito+ménsula
DG30552RD1DCS28+SV		14510-PH1-003	HONDA (Accord,Prelude)	Tensor-Correa/tiempo	30.00	55.00	•	30.50	•	30.5 mang.	Manguito+ménsula
DG30552RD1DCS28+SV1		14510-PH3-004	HONDA	Tensor-Correa/tiempo	30.00	55.00	•	33.50	•	33.5 mang.	Manguito+ménsula
DG30552RD1DCS28+SV1		14510-PH3-003	HONDA	Tensor-Correa/tiempo	30.00	55.00	•	33.50	•	33.5 mang.	Manguito+ménsula
DG30552RD1DCS28+V1		14510-PE0-005	HONDA	Tensor-Correa/tiempo	30.00	55.00	30.00	22.00	30.85	37.0 mang.	Manguito+ménsula
DG30552RD1DCS28+V1		14510-PE0-003	HONDA	Tensor-Correa/tiempo	30.00	55.00	30.00	22.00	30.85	37.0 mang.	Manguito+ménsula
DG3060312RR1HC2		FE1H-12-730A	MAZDA (626, '94)	TENSOR (1.8lt)	30.00	60.00	•	31.20	•	•	•
DG3060B2RKD1CS28+SV1		14510 PG6-013	HONDA	TENSOR	30.00	60.00	•	39.00	45.50	•	•
DG306216AW2RK1CS27		MB290585	Mitsubishi (Lancer, Minicab)	Rueda trasera int.	30.00	62.00	•	16.00	16.00	•	•
DG306216W-12RKCS		90043-63142	DAIHATSU	RUEDAS	30.00	62.00	•	16.00	16.00	•	•
DG306216W-12RKCS		0317-26-151	MAZDA	RUEDAS	30.00	62.00	•	16.00	16.00	•	•
DG306220BWC4		90043-63153	DAIHATSU	RUEDAS	30.00	62.00	•	20.00	16.00	•	•
DG306220BWC4		90043-63143	DAIHATSU	RUEDAS Tras.	30.00	62.00	•	20.00	16.00	•	•
DG3062DW2RSC4		90369-30021	TOYOTA	RUEDAS	30.00	62.00	•	24.00	•	•	•
DG3062DW2RSC4		90369-30013	TOYOTA	RUEDAS	30.00	62.00	•	24.00	•	•	•
DG3062DW2RSC4		9-00090-218	ISUZU	RUEDAS	30.00	62.00	•	24.00	•	•	•

Rodamientos rígidos de bolas de 1 ó 2 hileras -series DG, DDG- para diversas aplicaciones: ruedas, tensores y otras

Designación	Foto	Número de parte (O.E.M)	Fabricante	Aplicación	Dimensiones principales (unidad : mm)						Observación
					d	D	T ancho total	Bi ancho a.i.	Be ancho a.e.	B1. B ancho/ménsula	
DG3062DW2RSC4		9-00090-189	ISUZU	RUEDAS	30.00	62.00	•	24.00	•	•	•
DG3062DWCS39		47E-713D	CHRYSLER	N/D	30.00	62.00	•	24.00	21.00	•	Descontinuado
DG3062KWSH2C4		91052-SC2-014	HONDA	RUEDAS	30.00	62.00	•	18.00	22.00	•	•
DG3062W-12RSHR4SH2C4		N/D	TOYOTA	RUEDAS	30.00	62.00	•	24.00	16.00	•	•
DG3066ASH4-9TC3		N/D	YAMAHA	M.FUERA/ BORDA	30.00	66.00	•	16.00	16.00	•	Descontinuado
DG306725W2RSC4		90369-30057	TOYOTA	RUEDAS	30.00	67.00	•	25.00	17.00	•	•
DG3067AWCS39		Ref: 71BG1225BIB	FORD	N/D	30.00	67.00	•	24.00	24.00	•	Oburado. Aros extend.
DG3072232RKDNRS2Z		90363-30048	TOYOTA	RUEDAS	30.00	72.00	•	23.00	23.00	•	•
DG3078ANS2-9C3		93306-40080	YAMAHA	M.FUERA/ BORDA	30.00	78.00	•	19.00	19.00	•	•
DG3265A2RD1DCS39+Z		14510-PH7-003	HONDA	TENSOR	24.00	65.00	32.00	19.00	•	•	•
DG3265A2RD1DCS39+Z		14510-PH7-004	HONDA	TENSOR	24.00	65.00	32.00	19.00	•	•	•
DG3357-2		N/D	GENERAL ELECTRIC	LAVADORA	32.89	57.15	•	15.11	9.53	•	Descontinuado
DG3566SH2CS27		MD741659	MITSUBISHI	N/D	35.00	66.00	•	15.00	15.00	•	•
DG357217W2RK2SH4CS27		1312-26-151	MAZDA	RUEDAS	35.00	72.00	17.00	17.00	17.00	•	Descontinuado
DG357217WYA12RK2SH4CS27		Aplica 1312-26-151	MAZDA	RUEDAS	35.00	72.00	17.00	17.00	17.00	•	Descontinuado
DG357222DWC4		DOAZ1225A	FORD	RUEDAS	35.00	72.00	•	22.00	16.50	•	•
DG357222DWC4		09269-35009	SUZUKI (Jimmy-Samurai)	RUEDA TRAS.	35.00	72.00	•	22.00	16.50	•	•
DG357226W2RSC4		90369-35001	TOYOTA	RUEDAS	35.00	72.00	•	26.00	17.00	•	•
DG357226W2RS + C014		42410-12090	TOYOTA (Corolla, Sprinter)	RUEDA TRAS.	35.00	72.00	•	26.00	•	•	Con anillo adaptador
DG3572DW2RKBCS27		MB393919	MITSUBISHI	RUEDAS	35.00	72.00	17.00	17.00	17.00	•	Oburado (sello)
DG3572DW2RK + C014		MB073089	MITSUBISHI // Dodge	RUEDA TRASERA	35.00	72.00	64.00	17.00	17.00	64.00	Anillo adpatador
DG3572HWC4		8-94114-462, 8-94206-350	ISUZU //DELCO	RUEDA TRAS.	35.00	72.00	23.20	23.20	21.00	•	•
DG3572W-1SH2C4		MB569972	MITSUBISHI	RUEDA TRAS.	35.00	72.00	17.00	17.00	17.00	•	Sellos:2 lados (1 esp.)
DG3572W-3RSCS27		MR165476	MITSUBISHI	RUEDA TRAS.	35.00	72.00	22.00	22.00	22.00	•	Sello RS + Placa met.
DG358021WYAC4		90043-63100	DAIHATSU	RUEDAS	35.00	80.000	•	21.00	21.00	•	Rodam. abierto

Rodamientos rígidos de bolas de 1 ó 2 hileras -series DG, DDG- para diversas aplicaciones: ruedas, tensores y otras

Designación	Foto	Número de parte (O.E.M)	Fabricante	Aplicación	Dimensiones principales (unidad : mm)						Observación
					d	D	T ancho total	Bi ancho a.i.	Be ancho a.e.	B1, B ancho/ménsula	
DG358026WRKBC4		09269-35010	SUZUKI	RUEDA TRAS.	35.00	80.00	26.00	26.00	21.00	•	Obturado(aro int. ext.)
DG358028W2RSC4		90369-35085	TOYOTA	RUEDAS	35.00	80.00	•	28.00	21.00	•	•
DG3580AC4		90363-35022	TOYOTA	TRANSMISIÓN	35.20	80.00	21.00	21.00	21.00	•	Ref: 6307R
DG35852RKMDNSH2C3		90363-35023	TOYOTA (4.0 lt)	TRANSMISIÓN	35.00	85.00	23.00	23.00	23.00	•	Sellado(ranura a.e Trat. Térm. aro int.
DG3585D2RKMDNC3		90363-35030	TOYOTA	TRANSM.(Eje piloto)	35.00	85.00	23.00	23.00	23.00	•	Sellado(ranura a.e.)
DG3773 2RKB1CS38		N/D	FIAT Punto	Transm. (Transeje)	36.99	73.00	17.00	17.00	17.00	•	Radio chanf.a.i<normal
DG37802RKB1HHR4C3		92045-2235	KAWASAKI	RUEDAS	36.50	80.00	21.00	21.00	21.00	•	Ref.: 6208RRKB
DG37802RKB1HHR4C3		N/D	ISUZU	Transm.(eje entrada)	36.50	80.00	21.00	21.00	21.00	•	r a.i=0.3 mín.
DG4070A		93306-00805	YAMAHA	DIFERENCIAL	40.00	70.00	15.00	15.00	15.00	•	•
DG4072-1 2RKMD		N/D	TOYOTA (Land Cruiser '95)	Transmisión Automatica	40.00	72.00	17.00	17.00	17.00	•	Obturado
DG4072-1RKMD		N/D	TOYOTA (Land Cruiser '95)	Transmisión Automatica	40.00	72.00	17.00	17.00	17.00	•	Sello un lado
DG407214C3		90363-40024	TOYOTA/ Daihatsu	Diferencial	40.00	72.00	14.00	14.00	14.00	•	•
DG407216SH2C3		MD704597	MITSUBISHI	Transmisión	40.00	72.00	16.00	16.00	16.00	•	Abierto.Trat.Term a.i
DG407618HR4-9TCS20		91010-HC4-004	KEN-AS	TRANSM./ Remolque	40.00	76.00	17.50	17.50	17.50	•	•
DG408017A1NRSH2-TC3		MD724205	MITSUBISHI	RUEDAS	40.00	80.00	17.00	17.00	17.00	•	•
DG4080272RSE		N/D	N/D	N/D	40.00	80.00	•	27.00	21.00	•	Ref.: 88128RSE6
DG4080WRKBESH2C4		43591-65D00	SUZUKI	RUEDA	40.00	80.00	•	23.00	18.00	•	Anchos:23X18
DG409026W2RSHR4SH2C4		8-94446-781	ISUZU (Rodeo, Big Horn)	Rueda trasera int.	40.00	90.00	26.00	26.00	26.00	•	•
DG4092A2RKBDNSH2C3		90363-40035	TOYOTA	RUEDA	40.00	92.00	25.50	25.50	25.50	•	•
DG4092-12RJ8DNSH2C3		N/D	Toyota HI-LUX	Transm.(eje entrada) Mod R150	40.00	92.00	25.50	25.50	25.50	•	Ranura a.e.Sello acril. Radios a.i.<normal
DG4094W2RSHR4SH2C5		90363-40060	TOYOTA (Hi-Ace, 4X4)	RUEDA MOTRIZ	40.00	94.00	26.00	26.00	26.00	•	•

Rodamientos rígidos de bolas de 1 ó 2 hileras -series DG, DDG- para diversas aplicaciones: ruedas, tensores y otras											
Designación	Foto	Número de parte (O.E.M)	Fabricante	Aplicación	Dimensiones principales (unidad : mm)						Observación
					d	D	T ancho total	Bi ancho a.i.	Be ancho a.e.	B1. B ancho/ ménsula	
DG4094W-12RSHR4SH2C5		90363-40071	Toyota Hi-Ace 2005/6	RUEDAS	40.00	94.00	•	31.00	26.00	•	con pestaña
DG4180CS58		90903-63008	TOYOTA HILUX	Transmisión	41.00	80.00	17.00	17.00	17.00	•	•
DG4580BSH2C3		MD722537	MITSUBISHI// Hyundai	Transmisión Automatica	45.00	80.00	16.00	16.00	16.00	•	•
DG5080		93399-30080	YAMAHA	Ruedas	50.00	80.00	•	21.00	•	•	•
DG60932RD1HCS64+SV2		13503-65010, -65020	TOYOTA	Correa/Tiempo (Idler)	60.00	93.00	•	160.50	•	43 (brida)	Long. (brida)=161.0
Serie DDG.....											
DDG1538 2RDDL1S Z		N/D	NIPPON DENSO	ALTERNADOR	15.00	38.00	•	19.00	•	•	Exclusivo Nippon Denso
DDG1740A-1TC3		90363-17005	TOYOTA	MOTOR	17.00	40.00	•	24.00	24.00	•	•
DDG1752-12RDDL1CM		N/D	TOYOTA Estima	Alternador (del)	17.00	52.00	29.00	29.00	29.00	•	2 hileras de bolas
DDG30602RD1HCS25+SV1		FE3N-12-730	MAZDA (Telstar)	TENSOR (Idler)	30.00	60.00	30.00	30.00	32.00	•	•

► RODAMIENTOS AUTOMOTRICES

SERIE DG-DDG

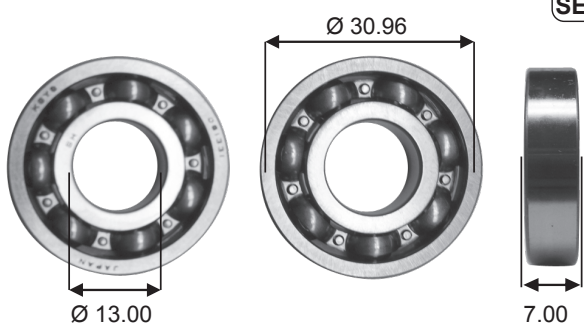

DG1331SH2C3

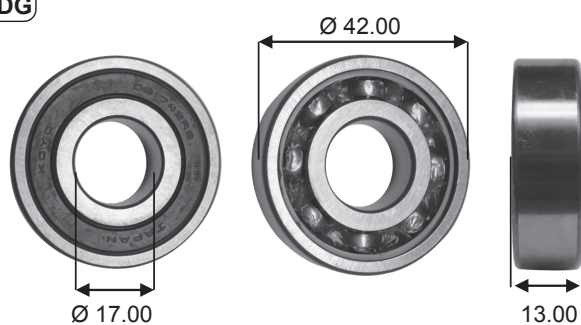

DG1742RSC3

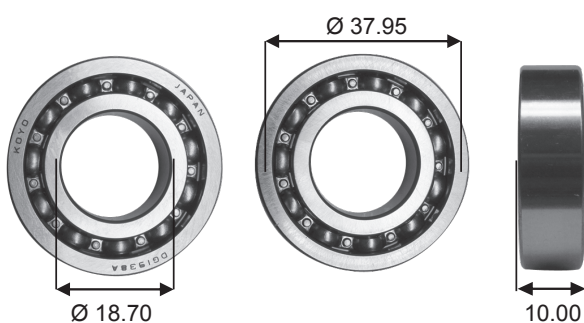

DG1938AC3

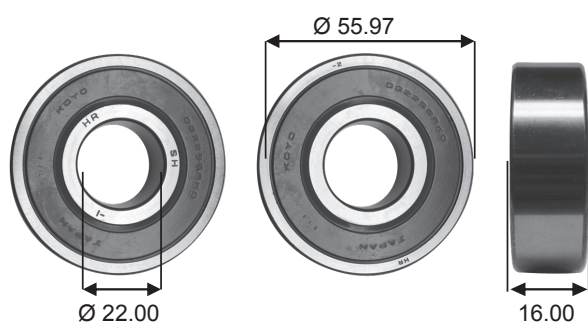

DG2256 - 22RKDHR4SHZ

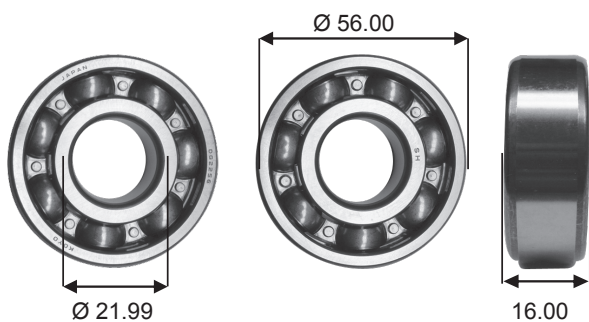

DG2256SH2C3

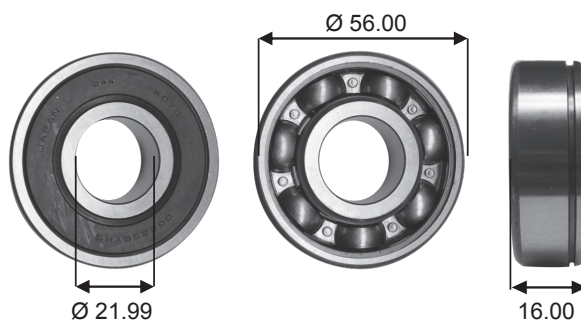

DG2256YRNRSC3

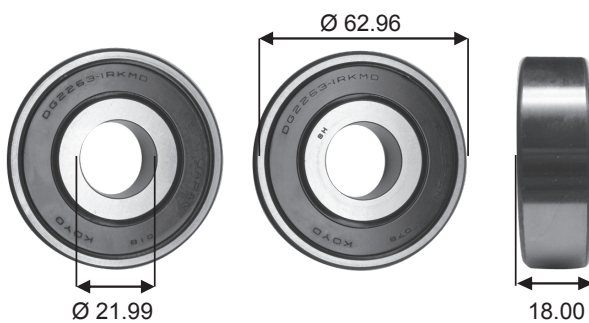

DG2263 - 12RKMDSH2C4

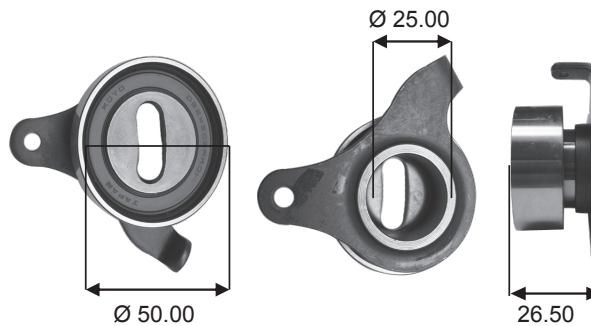

DG2450B2RKD1+SV

▶ RODAMIENTOS AUTOMOTRICES

SERIE DG-DDG

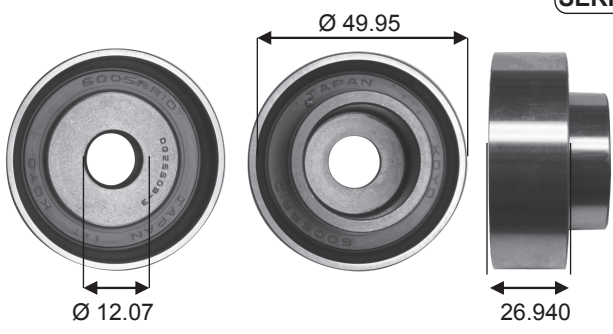

DG2550B - 32RR1D

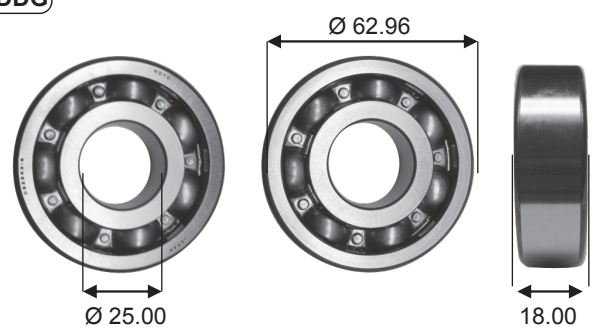

DG256318CS12

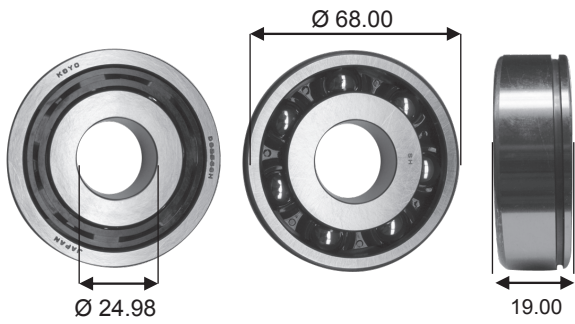

DG2568HNSH2C3

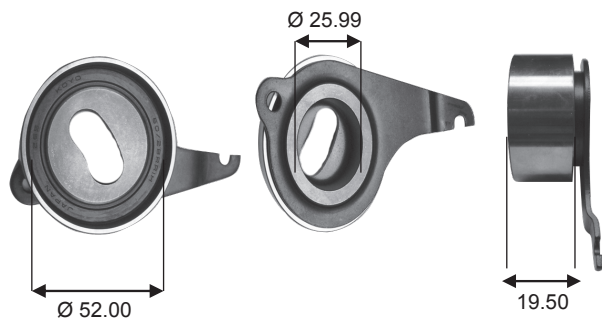

DG26522RR1H+SV

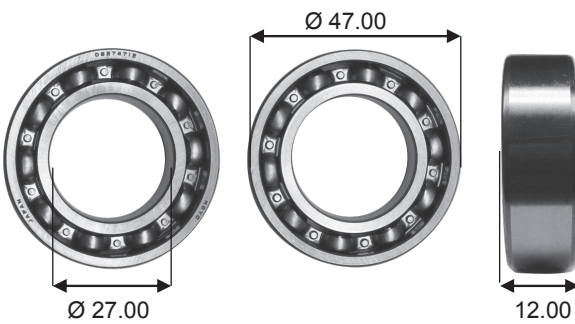

DG274712CS58

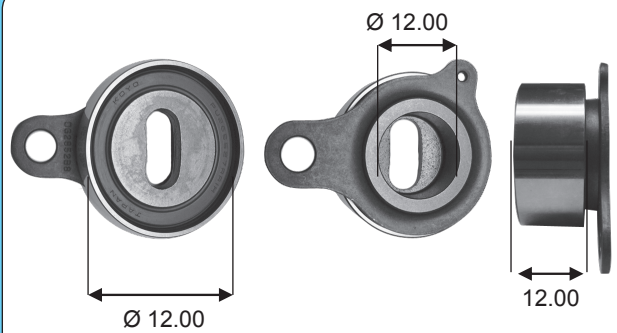

DG2852B82RR1H+SV1

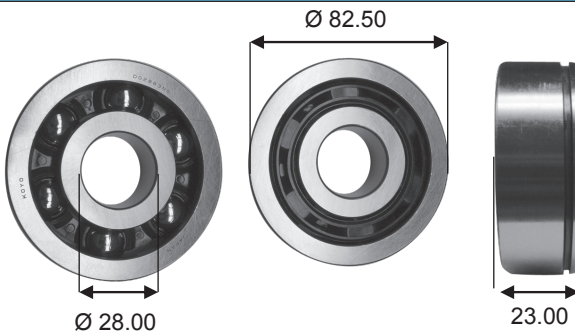

DG2883NS

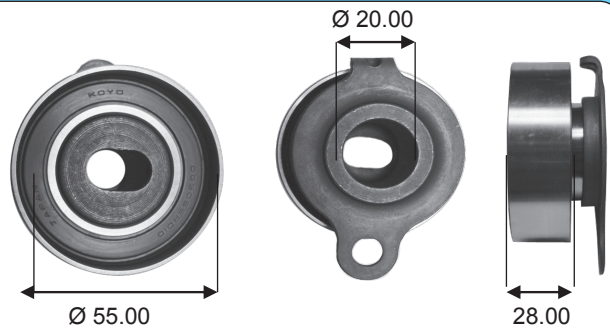

DG30552RD1DCS28+V1

► RODAMIENTOS AUTOMOTRICES

SERIE DG-DDG

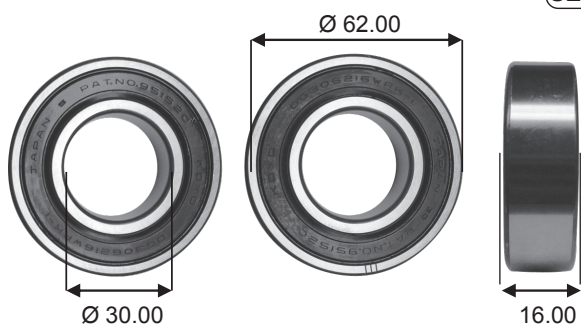

DG306216W - 12RKCS

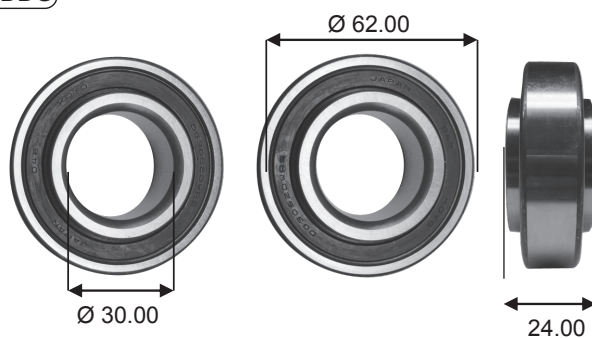

DG3062DW2RSC4

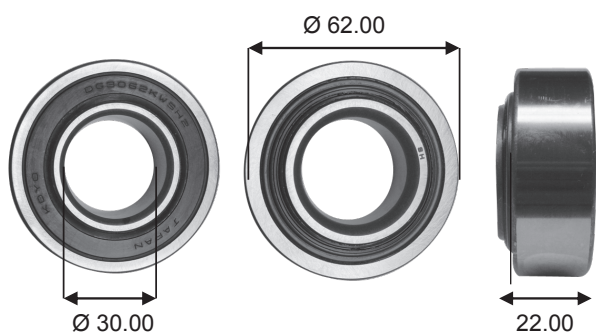

DG3062KWSH2C4

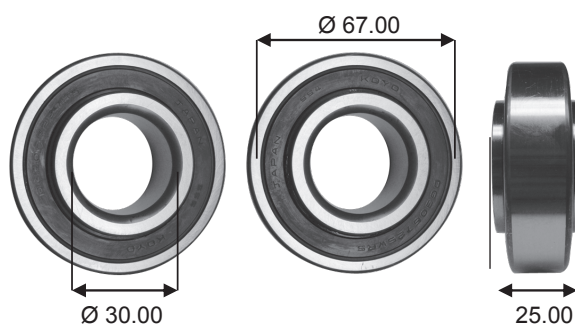

DG306725W2RSC4

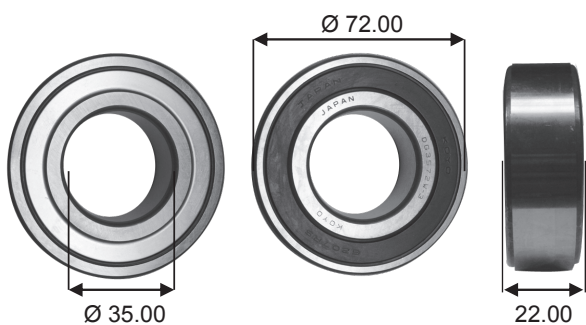

DG357222DWC4

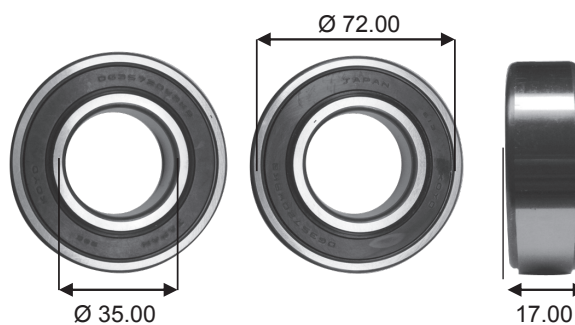

DG3572DW2RKBCS27

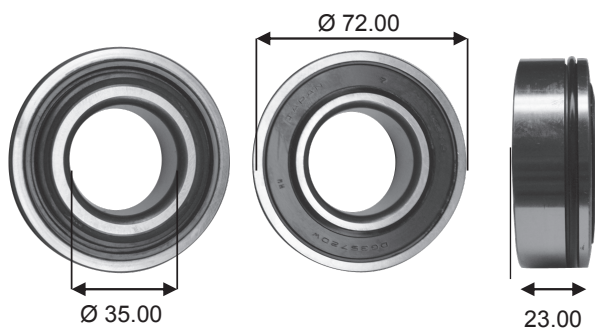

DG3572HWC4

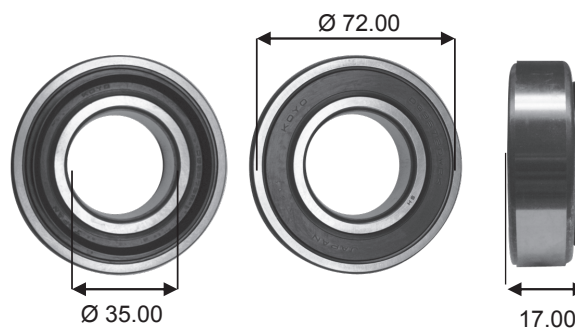

DG3572W - 1SH2C4

▶ RODAMIENTOS AUTOMOTRICES

SERIE DG-DDG

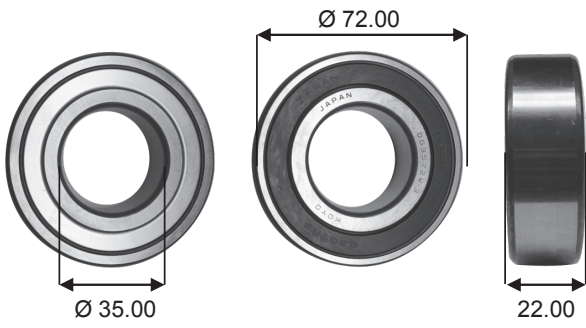

DG3572W - 3RSCS27

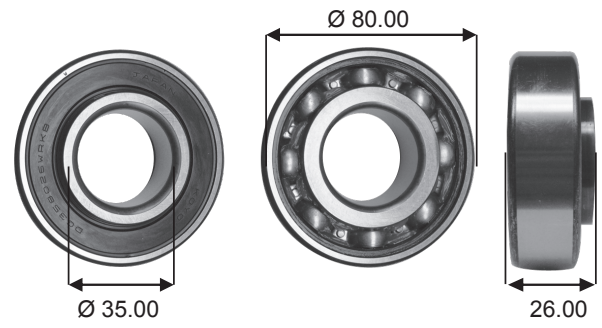

DG358026WRKBC4

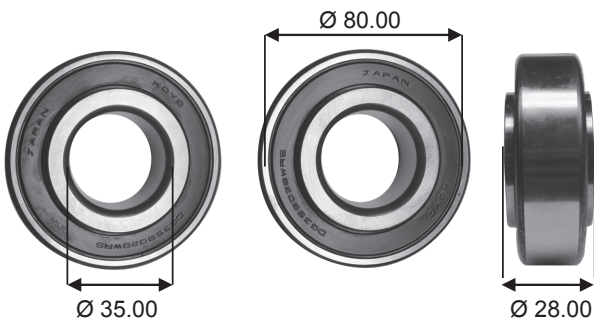

DG358028W2RSC4

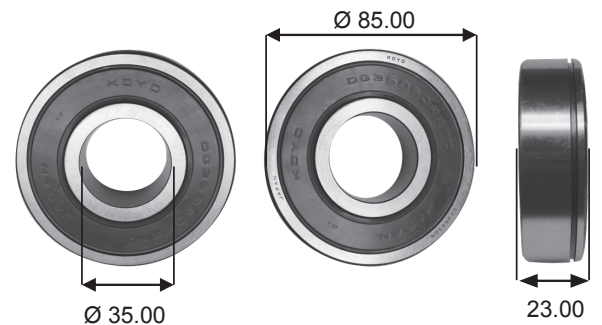

DG3585D2RKMDNC3

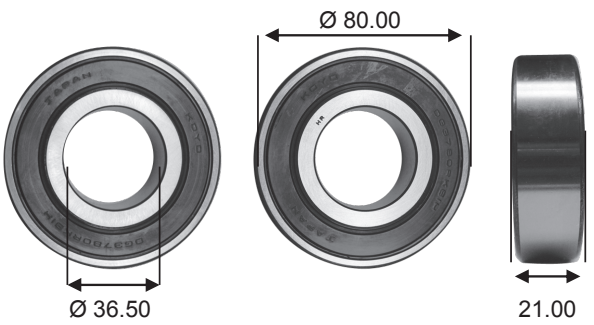

DG37802RKB1HHR4C3

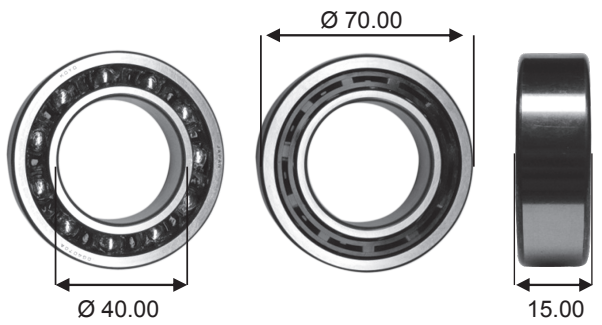

DG4070A

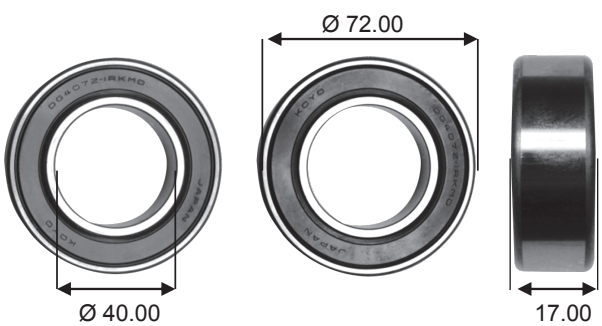

DG4072 - 1 2RKMD

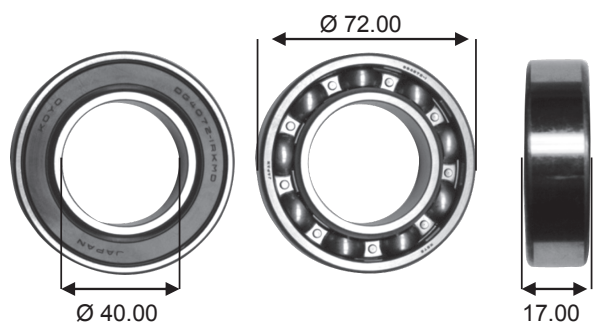

DG4072 - 1RKMD

► RODAMIENTOS AUTOMOTRICES

SERIE DG-DDG

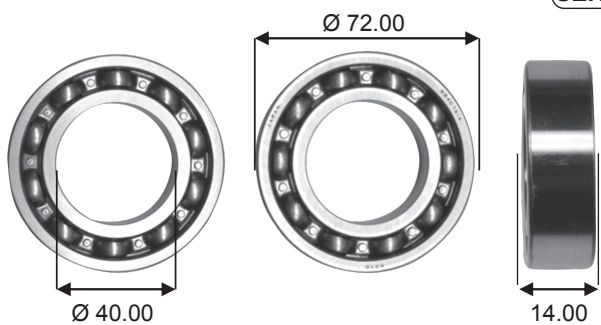

DG407214C3

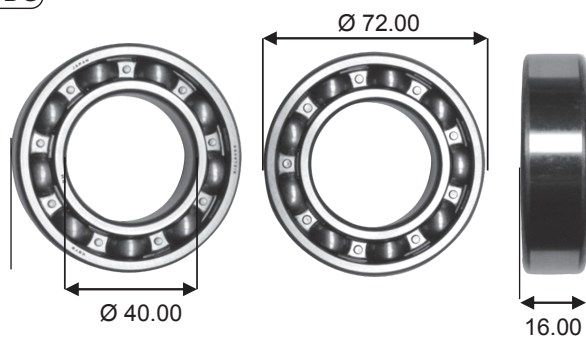

DG407216SH2C3

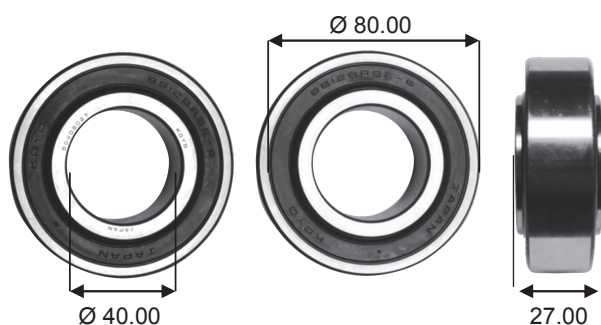

DG4080272RSE

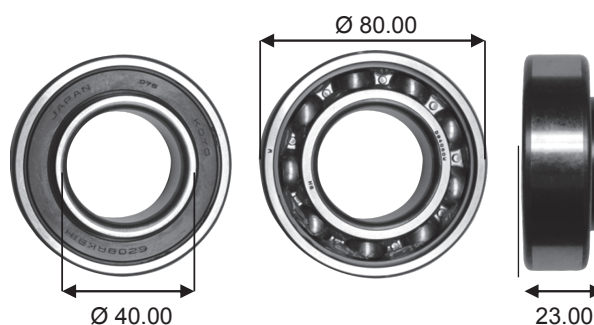

DG4080WRKBSH2C4

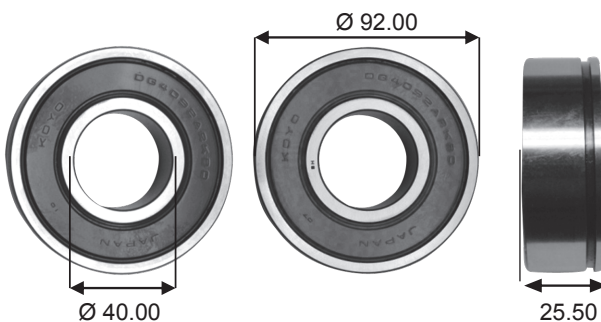

DG4092A2RKBDNSH2C3

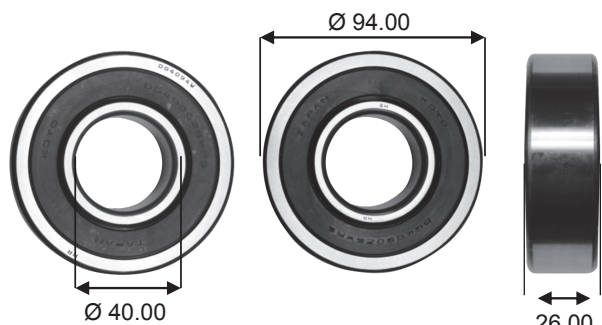

DG4094W2RSHR4SH2C5

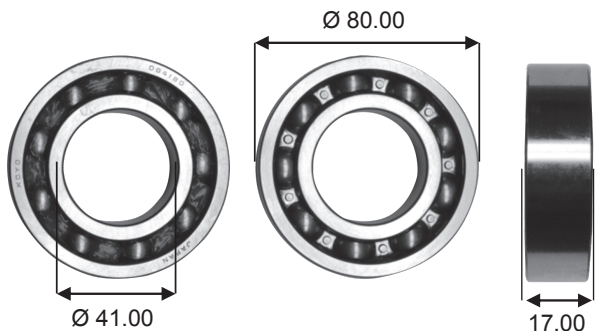

DG4180CS58

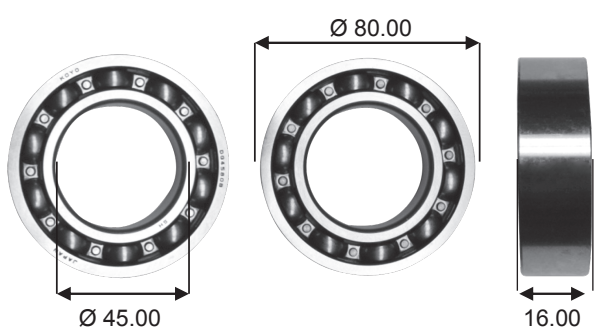

DG4580BSH2C3

▶▶ RODAMIENTOS AUTOMOTRICES

SERIE DG-DDG

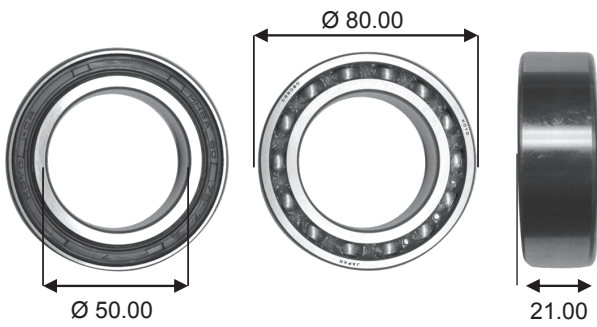

DG5080

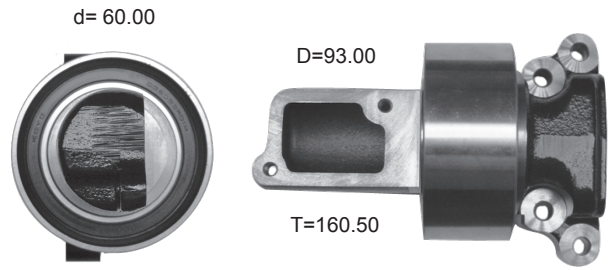

DG60932RD1HCS64+SV2